

CNC EXTERNAL CYLINDRICAL GRINDER PLUTO 18



PLUTO 18 is designed to meet below needs of the Industry

- Space Saving
- Competitive Grinding solution
- High performance
- Ease of operation

Machine is suitable to produce high precision shaft type parts in plunge / traverse grinding operations.

Easy to adopt various automation through gantry/robot.

Ergonomically designed for easy operation & Maintenance

MACHINE FEATURES

- Ease of operation through MGT's customized user-friendly Standard Graphics screen

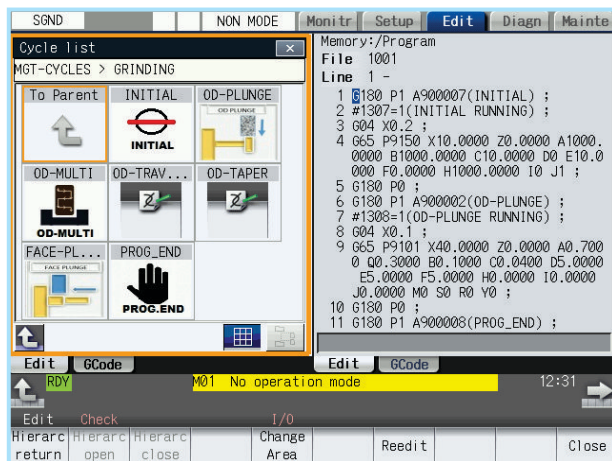

- Turcite lined guideways with recirculating type lubrication
- Tailstock having Job clamping by spring and retraction thru Hydraulic
- Machine with full guarding

MACHINE VARIANT AVAILABLE

- Straight Wheel Head
- Angular Wheel Head

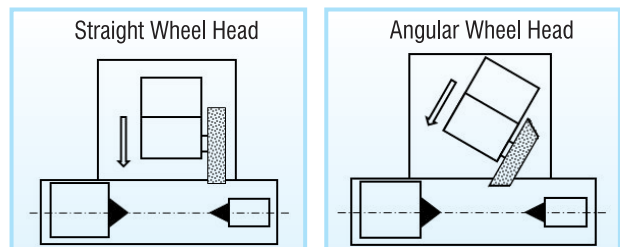

Machine Floor Plan (with standard coolant tank)

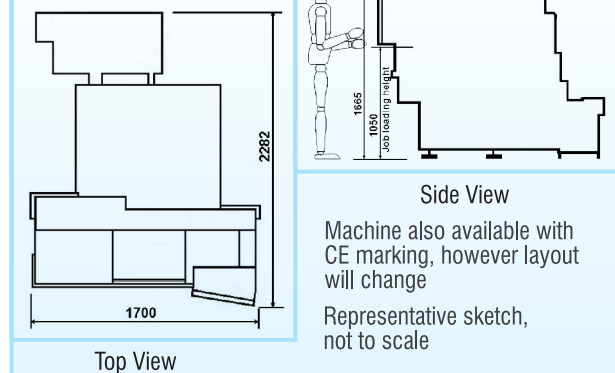

Options

- In process gauge (IPG)
- Linear positioner (Active flagging)
- Filtration system according to application
- Mist Collector
- Automation according to application

YOUR IDEAL CHOICE FOR CYLINDRICAL GRINDERS

Grinding Application Example

ANGULAR WHEEL APPROACH

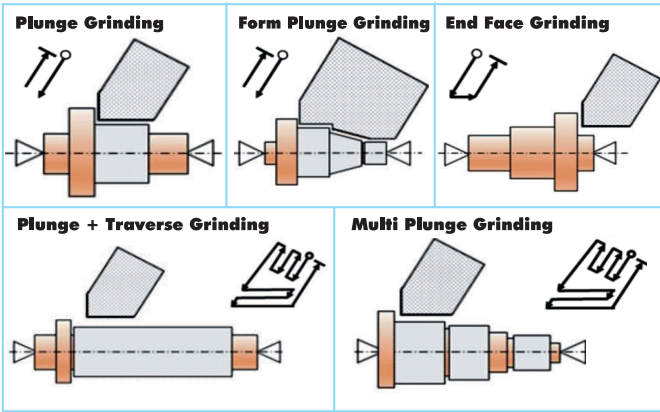

STRAIGHT WHEEL APPROACH

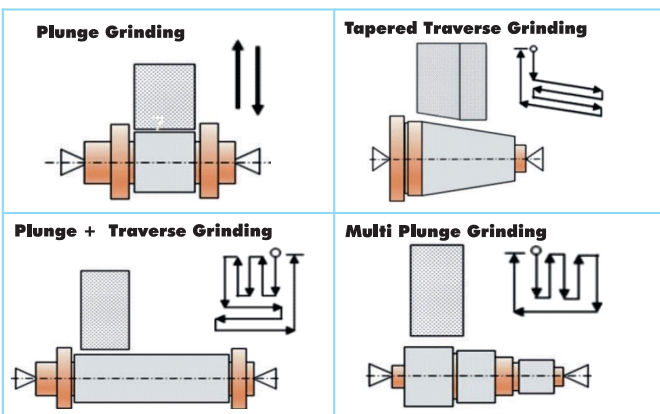

Machine Specifications

DESCRIPTION	UNIT	VALUE
Swing	mm	200
Grinding Diameter (Max. / Min)	mm	50 / 6*
Grinding length	mm	180
Admit between Centre	mm	230
(180mm grinding length towards tailstock side)		
GRINDING WHEEL HEAD		
Grinding wheel size (OD x Bore x Width)	mm	400 x 127 x 50
Wheel Peripheral Speed	M/sec	30
Spindle Motor Power	kW	3.7
Grinding Wheel Position		Straight / Angular
WORK HEAD		
Taper Bore	MT	4
Spindle Speed Range	RPM	90-1000
Type of Work head		Dead Center [Live]
TAIL STOCK		
Taper Bore	MT	3
Quill Travel	mm	25
Taper Correction Range	mm	±0.03
WHEEL HEAD X - AXIS		
Rapid Feed Rate (on diameter)	mm/min	10000
Minimum Incremental /Pulse	mm	0.001
Feed Servo Motor Torque	Nm	7
Type of Guide ways		V & Flat
		[LM Guideways -N O Type]
Z - AXIS		
Rapid Feed Rate (on diameter)	mm/min	10000
Minimum Incremental /Pulse	mm	0.001
Feed Servo Motor Torque	Nm	7
Type of Guide ways		V & Flat
GENERAL		
Operation Voltage	Volts	415±10 % AC 3 Ph
Machine Weight	Kg	2000
CNC		Mitsubishi [Fanuc]

NOTE :

[] Optional

- *Grinding of Diameter less than 6mm is also possible with special tooling's.
- Above specification as mentioned are to show machine capacity under standard operation conditions. In case of specific queries please contact MGT Representative

Since continuous development is taking place, design and specifications are subjected to change without prior notice and information



Head office
C-27 & 28, Industrial Area,
Meerut Road, Ghaziabad - 201003 (U.P.)
Tel.: +91-120-2712137
Fax: +91-120-2717823

Bangalore Plant
5/A, Survey No.74, 103, 106, 107
Somapura Village, Dabaspet Indl. Area,
Nelamangala Taluk, Bangalore-562 111
Karnataka
Ph: 080-27735385-87, Fax: 080-27735384

Marketed and Serviced by :
Micromatic®

New Delhi: Ph (011)22026874
E-mail: mmtdel@acemicromatic.com
Chennai: Ph (044) 40440700
E-mail: mmtche@acemicromatic.com
Bommasandra: Ph (080) 27834836
E-mail: mmtblr@acemicromatic.com
Mumbai: Ph (022)268681976
E-mail: mmtbom@acemicromatic.com
Indore: Ph 07389939190
E-mail: anilkmark@acemicromatic.com

Gurgaon: Ph (0124)4745500
E-mail: mmtdel@acemicromatic.com
Bangalore: Ph (080)40200555
E-mail: mmtblr@acemicromatic.com
Ranipet: Ph (04172)272732
E-mail: mmtche@acemicromatic.com
Pune: Ph (020)40712111
E-mail: mmtpune@acemicromatic.com
Nasik: Ph (0253)6610254
E-mail: mmtbom@acemicromatic.com

Faridabad: Ph (0129) 4033050
E-mail: mmtdel@acemicromatic.com
Coimbatore: Ph (0422) 4506183
E-mail: mmtcbe@acemicromatic.com
Tambaram: Ph (044)22265531
E-mail: mmtche@acemicromatic.com
Aurangabad: Ph (0240)2552309
E-mail: mmtaur@acemicromatic.com
Thane: Ph (022) 25889006
E-mail: mmtbom@acemicromatic.com

Ludhiana: Ph +91 9779128296
E-mail: pjbsales@acemicromatic.com
Belgaum: Ph (0831) 4203330
E-mail: mmtblr@acemicromatic.com
SriPerumbudur
E-mail: mmtche@acemicromatic.com
Rajkot: Ph (0281) 6548369
E-mail: mmtraj@acemicromatic.com
Chakan: Ph (02135) 322002
E-mail: mmtpune@acemicromatic.com

Rudrapur: Ph +91 95570 30224
E-mail: mmtukd@acemicromatic.com
Hyderabad: Ph (040) 27750496
E-mail: mmtblr@acemicromatic.com
Kolkata: Ph (033) 23648781
E-mail: mmtcal@acemicromatic.com
Kolhapur: Ph (0230) 2460444
E-mail: mmtkopsupport@acemicromatic.com
Jamshepur: Ph (0657) 6539931
E-mail: mmtcal@acemicromatic.com

E-mail: sales@micromaticgrinding.com

Website: www.micromaticgrinding.com

