

APOLLO

ACE
DESIGNERS

AceMicromatic®
Group Company



HORIZONTAL TURNING CENTER

Machine Features

- Cost effective CNC Turning Machine
- Rigid slant bed for easy chip disposal
- Precision LM Guideways on both the axes
- Cartridge type high speed spindle
- Bi-directional tool turret (8 station)
- Tailstock with hydraulic quill actuation
- Rapid rate of 15 m/min on both the axes
- Compact foot print suitable for cell manufacturing layout
- Easy Maintenance

Standard Accessories

- Automatic centralized oil lubrication
- Hydraulic power operated chuck
- Rigid tapping
- Drain line oil cooler
- Basic hydraulic system
- OD tool holder clamping block (8 nos)
- Boring bar holder (4 nos)
- Facing tool holder (2 nos)
- Set of sleeves

Optional Accessories

- Voltage stabilizer - 15 kVA
- Chip conveyor rear
- TPM - Trak productivity monitoring system
- Programmable quill
- 3 tier lamp

THINK Turning®
Ace Designers

THE LARGEST MACHINE TOOL GROUP IN INDIA



Follow us on :

www.acementromatic.net

Machining Range

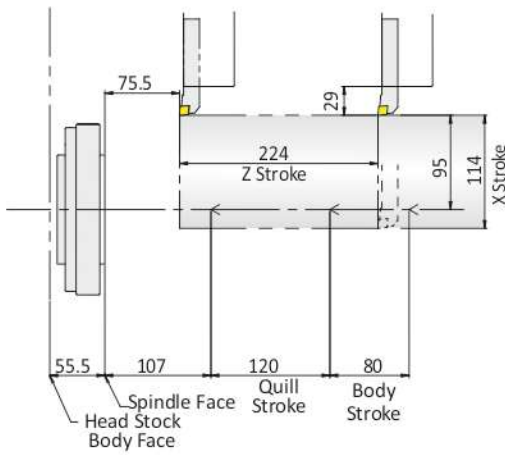

Interference Diagram

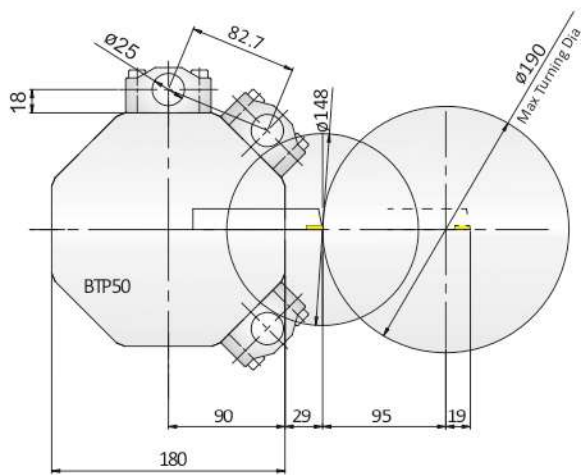

Overall View

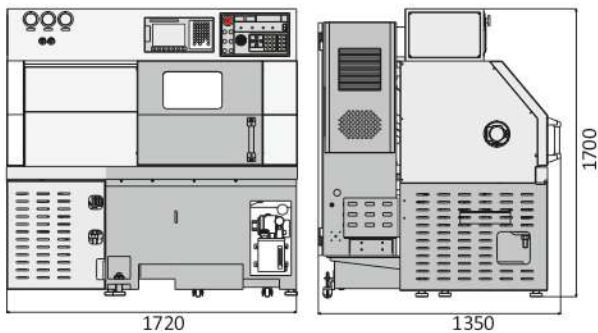

All Dimensions are in mm

Specifications

		Apollo	
CONTROL SYSTEM	Units	Fanuc / Siemens	
CAPACITY			
Swing Over Bed	mm	425	
Distance Between Centers ¹	mm	250	
Maximum Turning Dia	mm	190	
Between Centre Turning Dia	mm	165	
Maximum Turning Length ²	mm	224	
SPINDLE			
Spindle Nose		Flat 110	
Bore Through Spindle	mm	36	
Front Bearing Bore	mm	60	
Maximum Bar Capacity ³	mm	25*	
Maximum Spindle speed ³	rpm	4000	
Spindle Motor Power (F)-15 min (S) - S6-40% / S6-25% Rating)	kw	5.5 / 4.8 / 5.6	
Spindle Motor Power (Continuous Rating) (F/S)	kw	3.7/3.7	
Full Power Range (F/S)	rpm	1333-2333/1000-4000	
Standard Chuck Size	mm	135	
AXES			
Type of Guideways		Linear motion Guideways	
X-Axis Stroke	mm	114	
Z-Axis Stroke	mm	224	
X & Z Axes Rapid Rate	m/min.	15	
X Axis Ball Screw Dia And Pitch	mm	25 & 5	
Z Axis Ball Screw Dia And Pitch	mm	25 & 5	
X & Z Axes Motor Torque	Nm	2.6	
TOOLING			
Number of Tools Maximum		8	
Boring Bar Dia Maximum	mm	25	
OD Turning Tool Size	mm	16 X 16	
TAILSTOCK			
Tailstock Base Travel	mm	80	
Tailstock Quill Travel	mm	120	
Tailstock Quill Dia.	mm	50	
Quill Taper		MT-4	
Tailstock rotating centre type		Add-on	
Tailstock Thrust (Max)(@ 15 Bar)	kgf	150	
Coolant Tank Capacity	litre	60	
HYDRAULIC SYSTEM			
Hydraulic Pump Capacity	lpm	12	
Hydraulic Power Pack Tank Capacity	litre	20	
System Pressure	Kg/cm ²	30	
Overall Machine Dimensions (LxWxH)	mm	1720 X 1350 X 1700	
Overall Weight (Without Packing)	kg	~1850	

Specifications correct at the time of print. Owing to continuous up-gradation of our products, the specification may change and to be reconfirmed at the time of ordering.

1 Refer machining range diagram 2 With Appropriate Work holding.

3 Possible only with suitable work holding (F/S) - Fanuc / Siemens

Note: Features shown may not be part of the standard equipment.

Manufactured by:

Ace Designers Ltd.

Registered Office - Plot No.7 & 8, II Phase, Peenya Industrial Area, Bangalore - 560 058, India

Tel : +91-80-2218 6700, Fax : +91-80-2218 6723, E-mail : info@acedesigners.co.in, CIN: U29199KA1986PLC007816

INDIA-Marketed & Serviced by **Micromatic®**

Ahmedabad +91 7925471145; Ambattur +91 98407 85521; Aurangabad +91 240 2552309; Bangalore +91 80 40200555; Belgaum +91 99800 02597; Bommasandra +91 80 27834836;

Chakan +91 2135 322002; Chennai +91 44 40440700; Coimbatore +91 422 4506183, 6588595; Delhi +91 11 22414232/ 42448095; Faridabad +91 129 4047000; Gurgaon +91 124 4745500 / 4745500;

Hyderabad +91 40 23070496; Indore +91 73899 39190, 73899 39191; Jamshedpur +91 657 6539931; Kolhapur +91 230 2460444, 2460123; Kolkata +91 33 26710158 / 2710100 / 033-64578825

Ludhiana +91 97791 28296; Mumbai +91 22 26861009/1976/7271/7272; Nasik +91 253 6610254; Pune +91 20 40712111/27479661/9662; Rajkot +91 7698000728 Ranipet +91 4172 272732;

Rohtak +91 8295043311; Rudrapur +91 95570 30224, +91 97201 06532; Tambaram +91 44 22265531; Thane +91 22 25829062 Trichy +91 431 2443066 Chandigarh +91 99141 91057 Bhiwadi +91 99581 09777

INTERNATIONAL

Germany +49 (0) 172 231 6688 Shanghai +86 (21) 586 650 31/32; Switzerland +41 32 652 58 41

Email : salesmmt@acemicromatic.com

