

# DTC-400 XL

DRILL TAP MACHINING CENTER

High Productivity... Now Affordable...

**AMS**<sup>®</sup>  
In Pursuit of Excellence



\*Image subject to change design improvements.  
Image shown is without ATC top guard

## Standard Features

- Spindle Speed 10000 rpm
- 16 Tool Pocket Tilting type ATC
- Chip to Chip time - 1.7 sec
- BT-30/BBT-30
- Spindle Power 7.5 / 5.5 kW
- Rapid Traverse 60 / 60 / 48 m/min
- Roller Guideways
- Fanuc OiMF+ Package

## Optional Features

- Spindle Speed upto 24000 RPM
- 24 Tool Pocket Tilting Type ATC
- Chip to Chip time - 1.5 sec
- Automatic Pallet Changer - Linear / Rotary Type
- Coolant Through Spindle
- Chip conveyor
- Tool Washing
- Tooling up & Automation solutions

# DTC-400 XL - Drill Tap Machining Center

## Technical Specifications

Travels	Units	DTC-400 XL
X	mm	500
Y	mm	400
Z	mm	320
Dist. from spindle Face to table top	mm	120 - 440
<b>Table</b>		
Table size	mm	750 x 400
Max. load on table	Kg	300
Table height from floor	mm	885
<b>Spindle</b>		
Tool shank type		BT-30/BBT-30
Spindle speed - Std.	rpm	100-10000
- Opt.	rpm	Upto 24000
Spindle power - Std.	kW	7.5/5.5
- Opt.	kW	9/7.5/6
<b>Feed</b>		
Cutting feed	m/min	1 - 10
Rapid traverse	m/min	60 / 60 / 48
<b>Automatic tool changer</b>		
No. of tools - Std / Opt		16 / 24
Tool Dia. Max.	mm	80
Tool weight Max.	kg	2.5
Tool Length Max.	mm	250
Tool Change system		DISC ARMLESS
Chip to chip time - Std / Opt	sec.	1.7 / 1.5
<b>Accuracy(As per ISO 230-2)</b>		
Positioning accuracy	mm	0.010
Repeatability	mm	±0.003
<b>Control System</b>		
Fanuc	std.	0iMF+
<b>Installation data</b>		
Machine Width	mm	1600
Machine Depth	mm	2800
Machine Height	mm	2400
Machine Weight - Net	kg	3200

## Special features:

- Pocket tilting type ATC
- Wide door opening
- Easy loading
- Compact machine
- Totally enclosed guarding
- Liner pallet changer - 600 x 385mm (Optional)
- Rotary pallet changer - 600 x 400mm (Optional)

## Machine Layout

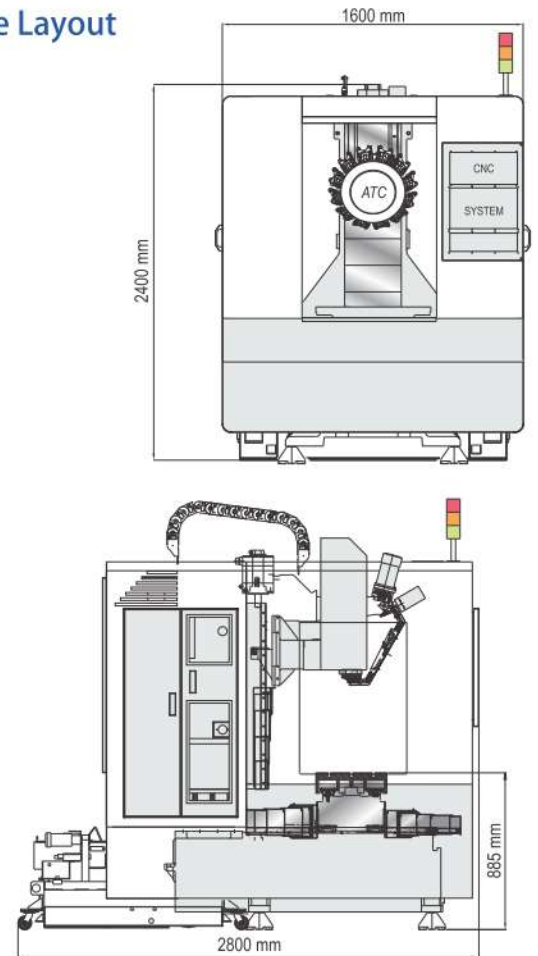

\*All specifications are subject to change without prior notice

## AMS<sup>®</sup> ACE MANUFACTURING SYSTEMS LTD.

Plot No. 467 - 469, 4th Phase, Peenya Industrial Area, BANGALORE - 560 058. INDIA.

Tel : +91-80-28360508 / 41828100, Fax: +91-80-28362791, E-mail : helpdesk@amslindia.co.in Website : www.amsl.in



A Green Co Gold Company  
awarded by CII

## INDIA-Marketed & Serviced by **Micromatic**

Ahmedabad +91 99242 89892; Ambattur +91 98407 85521; Aurangabad +91 240 2552309, 6511434; Bangalore +91 80 40200555; Belgaum +91 99800 02597; Bommasandra +91 80 27834836;

Chakan +91 2135 322002; Chennai +91 44 40440700; Coimbatore +91 422 4506183, 6588595; Delhi +91 11 22414232/ 42448095; Faridabad +91 129 4047000; Gurgaon +91 124 4745500 / 4745500;

Hyderabad +91 40 23070496; Pithampur +91 73899 39190, 73899 39191; Jamshedpur +91 657 6539931; Kolhapur +91 230 2460444, 2460123; Kolkata +91 33 23648781/82/83 /64578825;

Ludhiana +91 97791 28296; Mumbai +91 22 26861009/1976/7271/7272; Nasik +91 253 6610254; Pune +91 20 40712111/27479661/9662; Rajkot +91 281 6548369/2923048/3012775; Ranipet +91 4172 272732;

Rohtak +91 99966 91055; Rudrapur +91 95570 30224, +91 97201 06532; Tambaram +91 44 22265531; Thane +91 22 25889006; Trichy +91 9843265434, 9786016543

## INTERNATIONAL (exports-tsg@amslindia.co.in)

JTEKT TOYODA AMERICAS (Dealer)

T: +847 253 0340

E: groeder@toyoda.com

JTEKT TOYODA KOKI DO BRASIL (Dealer)

T: +55 (19) 99179-9336

E: rbortolucci@toyoda.com

MICROMATIC MACHINE TOOLS (SHANGHAI) CO. LTD. China

T: +86 (21) 5866 5031/32

E: raghuramachandran@acemicromatic.com

URAL TOOL PUMORI, Russia (Dealer)

T: (+90) 332 342 52 55

E: oleg@uipumori.ru

BAE YOUNG MACHINE (Dealer)

South Korea

T: (+82) 10 4789 1235

E: ryan.lee.hs@gmail.com

Visit us @[www.amsl.in](http://www.amsl.in)



/AceManufacturingSystems



/TheAcemanufacturing



/acemanufacturingsystemsltd



/ace-manufacturing-systems-india