

CNC INTERNAL GRINDERS

IG 50

IG 150

IG 150 U



WHO WE ARE

Established in 1973, Micromatic Grinding Technologies Ltd (MGT) have been manufacturing a wide range of External, Internal, Universal and Special Purpose Cylindrical Grinders in CNC, PLC and Hydraulic versions. These machines are built to the exacting requirements of our customers from its 4 plants in Ghaziabad near New Delhi and Bangalore in South India. Production CNC Centerless Grinders, Internal Grinders & Crankshaft Journal Grinders have also been added to expand the range of new machines being offered from the 4th new plant at Bangalore started in 2008. Since 2005, MGT has emerged as the market leader with nearly 50% market share in India.

Four decades of building an organisation Culture of ethical & transparent working, combined with the pursuit of excellence, drives Team MGT towards its vision of "Becoming the Best."

We at MGT are constantly seeking new avenues to partner, acquire latest technology, skills and quality-centric processes to co-create value & your success.

4000 machines delivered worldwide with many repeat references from a Global customer list, stand as a testimony to customer's preference for Micromatic Grinding machines.

ULTIMATE PRECISION & FLEXIBILITY IN GRINDING



Work Sample	Connecting Rod
Roundness	2 μm (Stock removal 0.3)
Cylindricity	3 μm
Surface Roughness	0.3 $\mu\text{m Ra}$



Work sample	Idler Gear
Cylindricity	3 μm
Surface Roughness	0.2 $\mu\text{m Ra}$



Work sample	Piston
Peripheral speed	33 M/s
Cylindricity	5 μm
Surface Roughness	0.4 $\mu\text{m Ra}$

CNC INTERNAL GRINDERS

High precision 2/3 Axes CNC Cylindrical Internal Grinding Machines are ideal for variety of internal / external and face grinding applications.



IG 50



IG 150



IG 150 U

FEATURES

- Box structure cast iron bed for high stability and good damping characteristics
- Completely enclosed guard for better environmental control
- Twin spindle application for grinding stepped bore of different ranges in single setup (IG-50/IG150)
- Compact foot print with machine mounted accessories for plug & start
- Precision Antifriction work head with spindle locking arrangement for easy change of work holding devices
- Automation with Robot / Gantry

FEATURES

Machine Bed

Cast iron machine bed is designed and tested through FEA analysis for rigidity, vibration & thermal stresses ensuring consistent machine performance with high accuracy for life



Work Head

- Spindle with high precision bearings which are grease packed and pre-loaded for better stiffness
- In-built hydraulic cylinder for clamping/de clamping of chuck for vibration free rotation at higher speed (A2-4, A2-5)
- Gear mechanism with Pneumatic lifting provision for easy swivelling of the work head during setup & resetting (IG-150/ IG-150 U)

Servo Driven (Option)



IG-50

Induction Motor Driven (Option)



IG-150

Internal Grinding Spindle

Belt Driven Spindle

- Belt driven spindle (7,500 to 35,000 rpm) with grease packed / Air-oil lubrication for bearings, clamped in rigid housing and driven through induction/ spindle servo motor

HF Spindle (Optional)

- High frequency spindles with 18,000rpm to 1,05,000rpm are offered for higher material removal ensuring consistent, enhanced quality



External Grinding

Wheel Head (Only for IG-150 U)

- The wheel head spindle runs on high precision multipoint hydrodynamic bearings which gives very high rigidity & excellent damping (as an option, spindle with high precision angular contact bearings is also available)
- The spindle is made of Nitriding steel, specially heat treated to achieve very high dimensional stability, accuracy and long life



Infeed & Traverse Slide (X, Z1 & Z2 Axis) (IG-50/IG-150 U)

- Both slides are a 3 piece modular construction. They are provided with SS covers for better coolant protection and longer life
- Faster oscillation of slides due to low inertia / moving mass
- The slides move on high precision anti-friction, pre-loaded linear guide ways to deliver micronic response with high rigidity
- Servo motor is directly coupled to pre-loaded ball screw to ensure backlash free motion
- High precision linear encoder can be provided (option) for direct feedback to the CNC System and higher position accuracy
- Telescopic cover on slides have been avoided to ensure lower friction and better accuracies

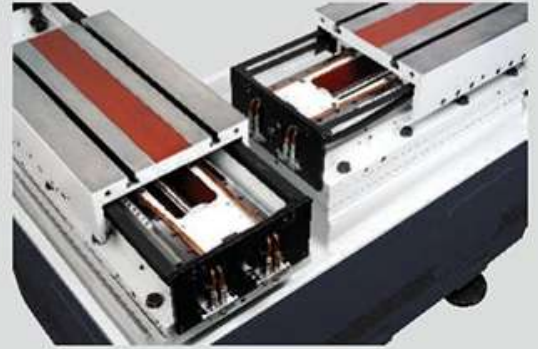

Cross Axis (IG-150)

- Cross Axis Slide is a 4 piece modular construction. It is provided with SS covers for longer life
- The slides move on high precision anti friction pre-loaded linear guide ways to deliver good step response with high rigidity
- Servo motor is directly coupled to the pre-loaded ball screw to ensure backlash free motion
- A high precision linear encoder can be provided as an option for direct feedback to the CNC system and higher position accuracy

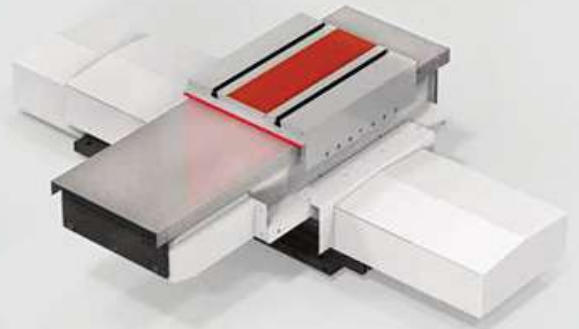

Dresser

- Dresser mounting ensures higher rigidity and better size control
- Pneumatic / Hydraulic operated swing down dresser can be provided as an option
- Rotary dresser can be provided as an option for better dressing accuracies



CNC System

- The machine is offered with FANUC or SIEMENS or Mitsubishi CNC system with A.C. servo motor & drive and inbuilt absolute rotary encoder
- The machine cabinet & operator panel are conveniently mounted on the machine for 'Plug & Start' operation thereby reducing the installation time
- The operator console has been ergonomically designed for ease of operation



AXIS CONFIGURATION

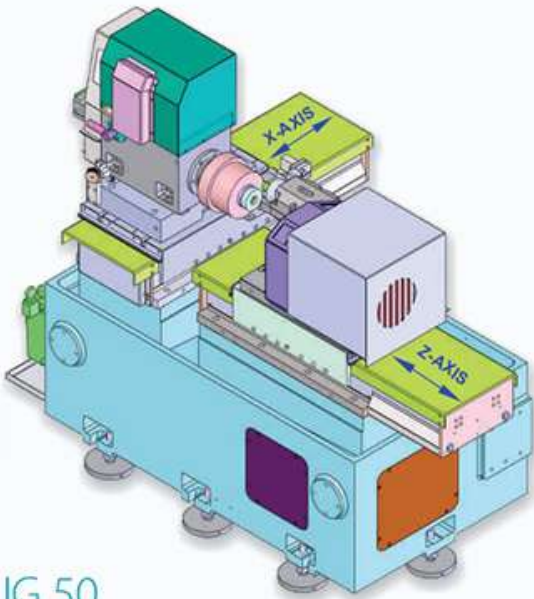

IG 50

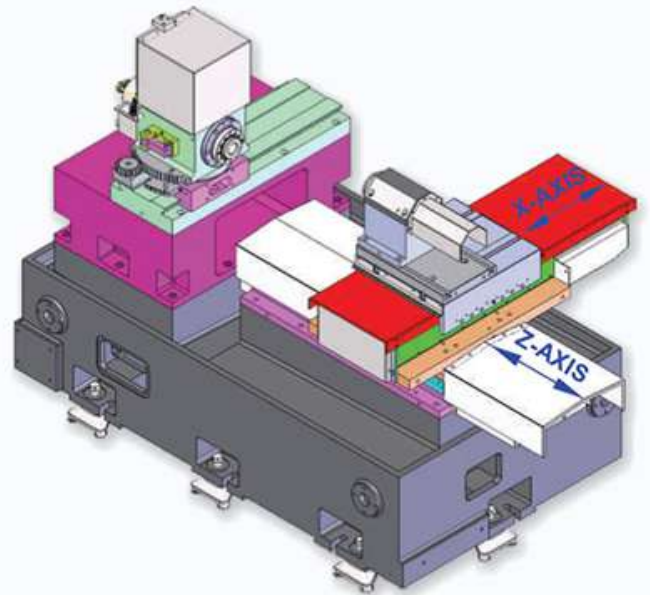

IG 150

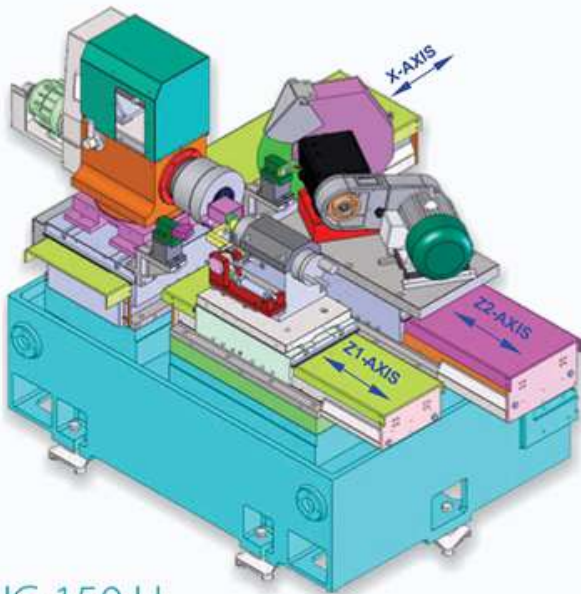

IG 150 U

OPTIONAL ACCESSORIES

- Gap and Crash
- Dynamic Wheel Balancer for External Wheel Head
- In Process Gauging
- Linear Scale for X, Z1 and Z2- Axes
- Automation with Robot / Gantry

MACHINE LAYOUT

IG 50

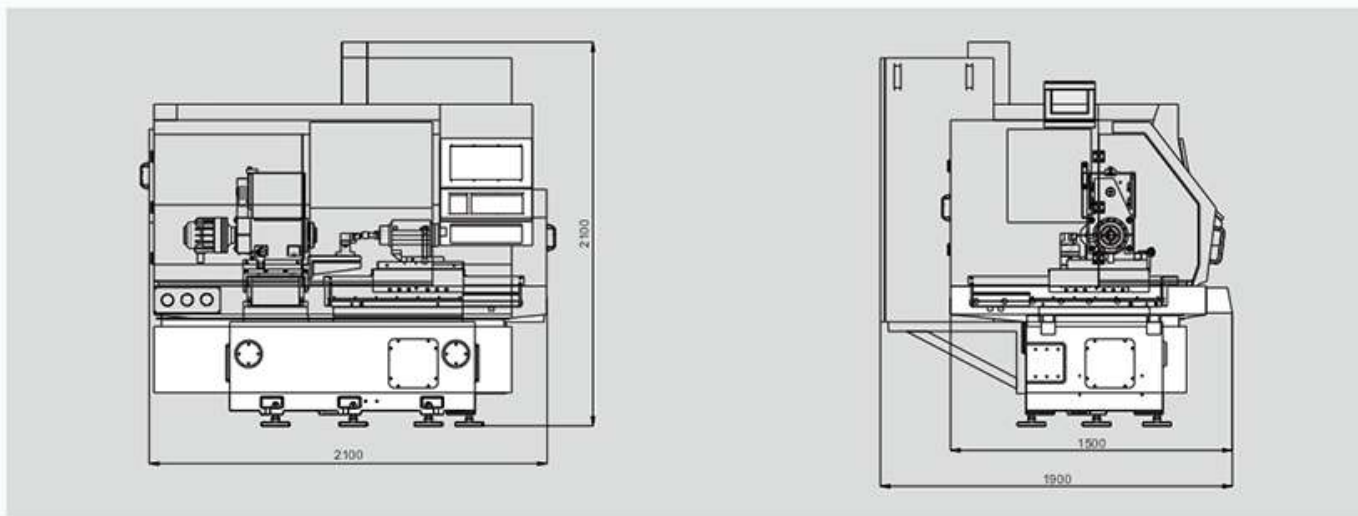

IG 150

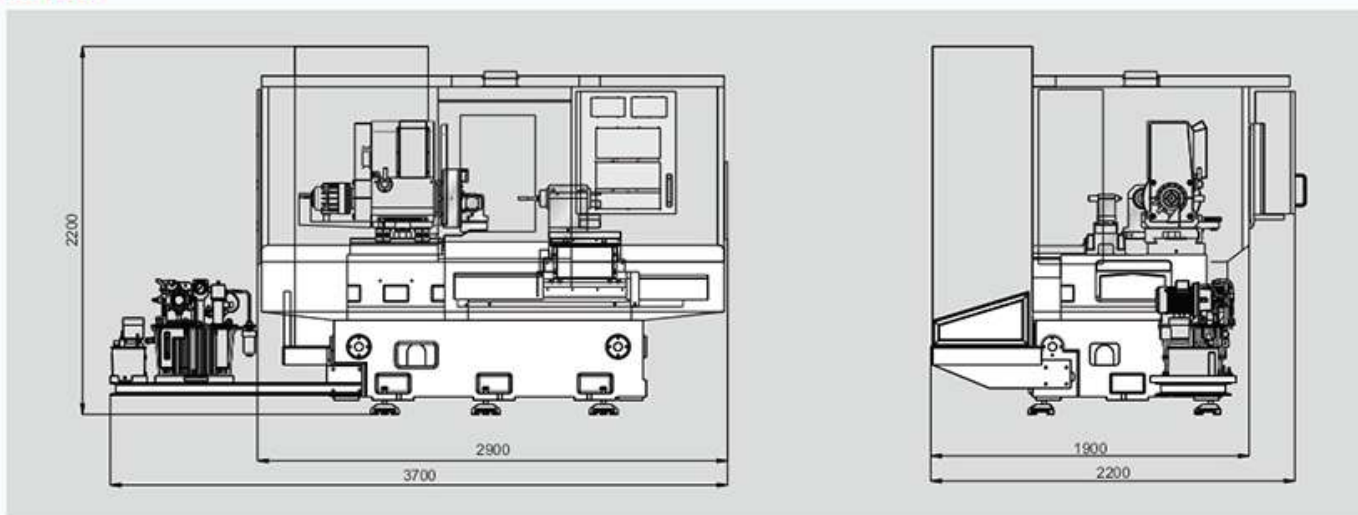

IG 150 U

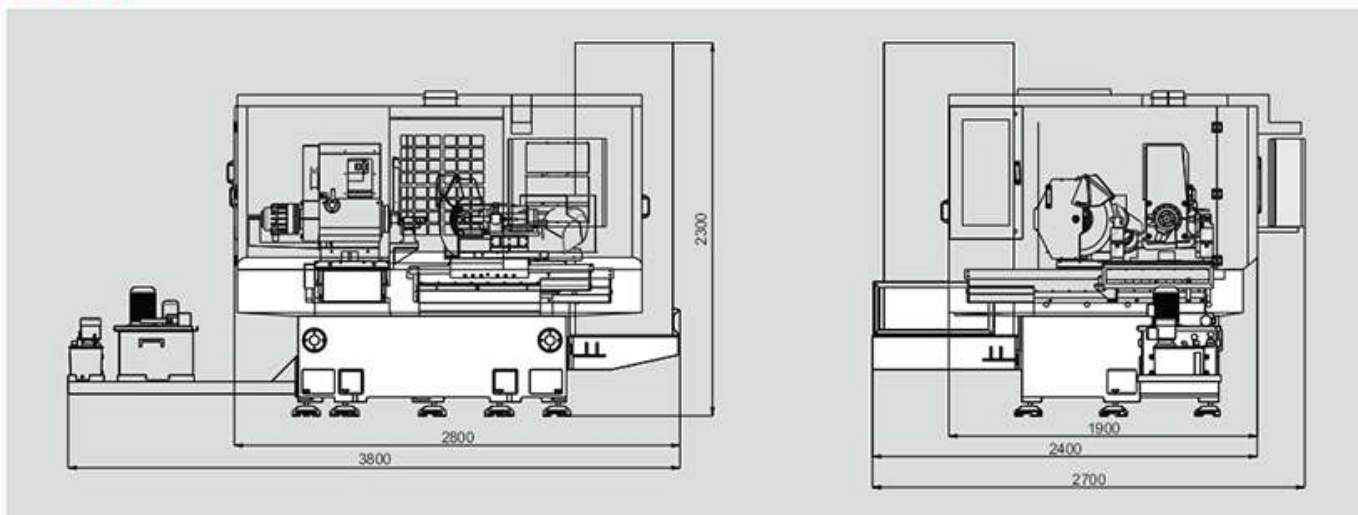

APPLICATIONS



IG-50/IG-150

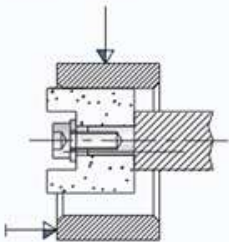

Plain Bore

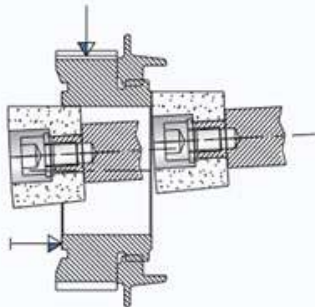

Plain Bore & Face

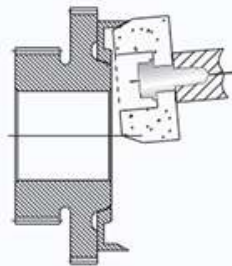

Chamfer

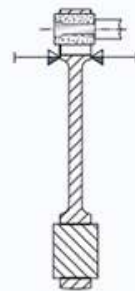

Connecting Rod Bore

IG-150 U

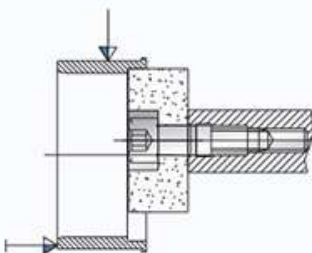

Stepped Bore

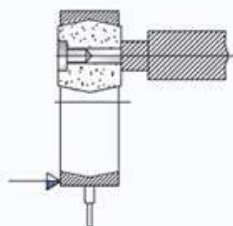

Bearing Trac

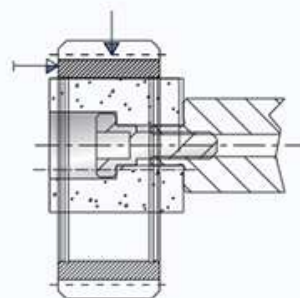

ID Grinding

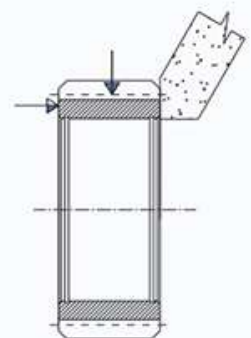

Face Grinding

SPECIFICATIONS

		IG-50	IG-150	IG-150 U
Capacity				
Maximum swing dia of chuck	mm	170(250)	300(450,600)	300(450,600)
Maximum bore grinding dia. (with suitable internal spindle)	mm	50(70)	150(250)	150(200)
Minimum bore grinding dia. (with suitable internal spindle)	mm	5	5	5
Grinding length	mm	70	200	120
OD grinding wheel size	mm	--	--	Ø400 X 127
Maximum component weight (Including chuck)	kg	40(70)	70(110,150)	110
Cross table In feed (X axis)				
Table stroke	mm	250	300	500
Rapid feed rate	m/min	10	10	10
Minimum increment /pulse	mm	0.001	0.001	0.001
Type of guide ways		Cross roller	Cross roller	Cross roller
Feed servo motor torque	Nm	7	7	11
Longitudinal table (Z axis) ID				
Table stroke	mm	250	350	300
Rapid feed rate	m/min	10	10	10
Minimum increment /pulse	mm	0.001	0.001	0.001
Type of guide ways		Cross roller	LM	Cross roller
Feed servo motor torque	Nm	7	7	7
Longitudinal table (Z1 axis) OD				
Table stroke	mm	-	-	300
Rapid feed rate	m/min	-	-	10
Minimum increment /pulse	mm	-	-	0.001
Type of guide ways		-	-	Cross roller
Feed servo motor torque	Nm	-	-	7
Work Head				
Spindle nose	No.	A2-4(A2-5)	A2-5(A2-6, A28)	A2-6
Motor torque	Nm	7	11(20)	11(20)
Internal grinding wheel head				
Belt driven spindle				
Spindle speed	rpm	7500-35000	7500-35000	7500-35000
Spindle power	kW	2.2	5.5	2.2
Lubrication		Grease packed/Oil mist	Grease packed/Oil mist	Grease packed/Oil mist
HF Spindle (Optional)				
Spindle speed	rpm	18,000 - 1,05,000	18,000 - 1,05,000	18,000 - 1,05,000
Lubrication		Air oil lubrication	Air oil lubrication	Air oil lubrication
General				
CNC control system		Fanuc/Siemens/ Mitsubishi	Fanuc/Siemens/ Mitsubishi	Fanuc/Siemens/ Mitsubishi
Operation voltage	Volts	415 + 10 % AC 3 phase	415 + 10 % AC 3 phase	415 + 10 % AC 3 phase
Machine weight	kg	2500	4500	5000

Since continuous development is taking place, design and specifications are subjected to change without prior notice and information
Colour shown in picture may not match with actual colour due to printing limitations



Head Office

Micromatic Grinding Technologies Ltd.
C- 27 & 28, Industrial Area, Meerut Road, Ghaziabad-201003
Uttar Pradesh
T: +91 20 2712137 / 69 / 79, 2723216
E: sales@micromaticgrinding.com

Bangalore Plant

Micromatic Grinding Technologies Ltd.
5/A, Survey No. 74, 103, 106, 107 KIADB, Industrial Area, Nelamangala Taluk,
Bengaluru, Karnataka 562111
T: +91 80 27735383 / 85 / 86 / 87 / 88
E: sales@micromaticgrinding.com

E-mail: sales@micromaticgrinding.com

Website: www.micromaticgrinding.com

Marketed and Serviced by : MICROMATIC MACHINE TOOLS PVT. LTD. INDIA

NORTH

Delhi
T: +91 11 22414232
E: mmtdel@acemicromatic.com

Gurgaon
T: +91 124 4745500
E: mmtdel@acemicromatic.com

Rohtak
T: +91 99966 91055
E: mmtdel@acemicromatic.com

Faridabad
T: +91 129 4047000
E: mmtdel@acemicromatic.com

Ludhiana
T: +91 97791 28296
E: mmtdel@acemicromatic.com

Rudrapur
T: +91 95570 30224
E: mmtukd@acemicromatic.com

SOUTH

Bangalore
T: +91 80 40200555
E: mmtblr@acemicromatic.com

Chennai - Sriperumbudur
T: +91 44 40440700
E: mmtche@acemicromatic.com

Ranipet
T: +91 4172 272732
E: mmtrpt@acemicromatic.com

Bangalore - Bommasandra
T: +91 80 27834836
E: mmtbms@acemicromatic.com

Chennai - Tambaram
T: +91 044 22265531
E: mmtche@acemicromatic.com

Trichy
T: +91 431 2483066
E: mmtry@acemicromatic.com

Belgaum
T: +91 99800 02597
E: mmtbgm@acemicromatic.com

Coimbatore
T: +91 422 4506183, 6588595
E: mmtcb@acemicromatic.com

Chennai - Ambattur
T: +91 44 40440700
E: mmtche@acemicromatic.com

Hyderabad
T: +91 40 23070496
E: mmthyd@acemicromatic.com

EAST

Jamshedpur
T: +91 657 6539931
E: mmtcal@acemicromatic.com

Kolkata
T: +91 33 23648781
E: mmtcal@acemicromatic.com

WEST

Ahmedabad
T: +91 99242 89892
E: mmtbom@acemicromatic.com

Pune - Chakan
T: +91 21 35322002
E: mmtpune@acemicromatic.com

Mumbai - Thane
T: +91 22 25829062
E: mmtbom@acemicromatic.com

Aurangabad
T: +91 240 2552309
E: mmtaur@acemicromatic.com

Pune - Chinchwad
T: +91 20 40712111
E: mmtpune@acemicromatic.com

Pune - Shirur
T: +91 98906 23217
E: mmtpune@acemicromatic.com

Indore
T: +91 73899 39190
E: mmtindr@acemicromatic.com

Kolhapur
T: +91 230 2460444
E: mmtkop@acemicromatic.com

Rajkot
T: +91 281 6548369
E: mmtraj@acemicromatic.com

Nasik
T: +91 253 6610254
E: mmtbom@acemicromatic.com

Mumbai
T: +91 22 26861009
E: mmtbom@acemicromatic.com

INTERNATIONAL

Germany
T: +49 1722316688
E: debjoyr@acemicromatic.com

China (Shanghai)
T: +86 (21) 5866 5031/32
E: raguramachandranc@acemicromatic.com

Follow us at



[www.facebook.com / micromaticgrindingtech](http://www.facebook.com/micromaticgrindingtech)



<http://tinyurl.com/zgn8wvt>



<http://tinyurl.com/z7264wo>