

SLC 20 LM SPT

DIFFERENTIAL CASE SPHERICAL TURNING

ACE
DESIGNERS

AceMicromatic
Group Company



HORIZONTAL TURNING CENTER

Machine Features

- Powerful AC spindle motor
- High speed spindle
- Thermally stabilised spindle
- Linear motion guideways
- 30 m/min axes rapid traverse rate
- Pre-tensioned ball screw support
- 100% ball bar tested
- Separate coolant tank for easy maintenance
- 3 point support for easy levelling
- Special 4-station servo turret

Standard Accessories

- AC spindle & axes drives
- Automatic centralized oil lubrication
- Drain line oil cooler
- Basic hydraulic system
- Boring bar holder $\varnothing 40$ (4 nos)
- Safety door interlock
- AC unit for electricals
- 3 tier lamp

Optional Accessories

- Voltage stabilizer
- Chip conveyor (Rear mount)
- TPM - Trak productivity monitoring system
- Laser calibrated axes
- Auto door

THINK Turning®
Ace Designers

THE LARGEST MACHINE TOOL GROUP IN INDIA



Ace Designers



@acedesignersblr



@acedesigners



Follow us on :

www.acemicromatic.net

Machining Range Diagram

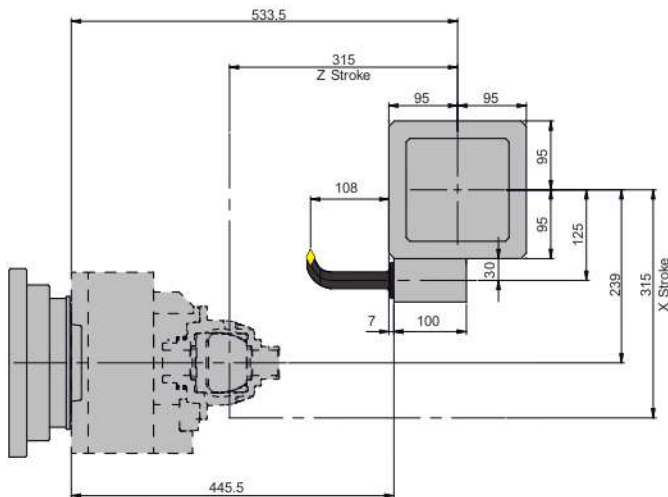

Power Torque Diagram

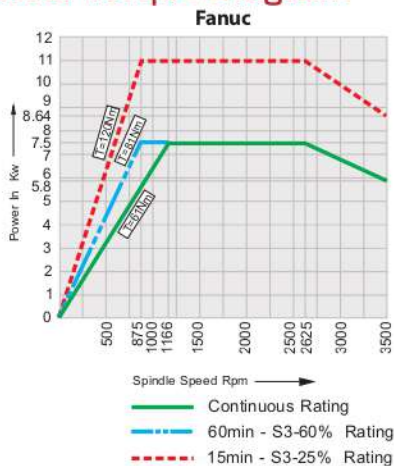

Overall Views

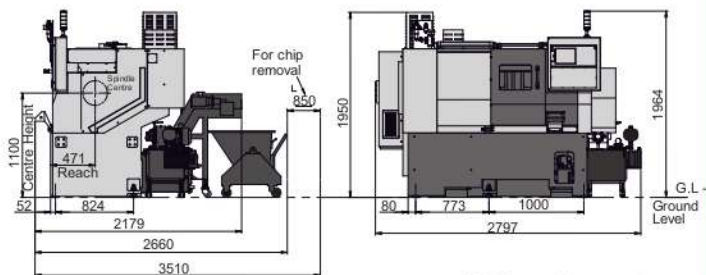

All dimensions are in mm

Specifications

SLC 20 LM SPT

Control System	Fanuc
Capacity	
Swing Over Table	Ø270 mm
Swing Over Carriage	Ø400 mm
Spindle	
Spindle Nose	A2-6
Bore Through Spindle	Ø63 mm
Front Bearing Bore	Ø100 mm
Maximum Bar Capacity*	Ø51 mm
Maximum Spindle Speed*	3500 rpm
Spindle Motor Power (15 min. Rating)	11 kW
Spindle Motor Power (Continuous Rating)	7.5 kW
Full Power Range	1166 - 2625 rpm
Maximum Chuck Size	Ø250 mm
Axes	
Type of Guideways	Linear Motion Guideways
X-Axis Stroke	315 mm
Z-Axis Stroke	315 mm
X & Z Axes Rapid Rate	30 m/min.
Tooling	
Turret Type	4 Station Servo
No of Tools	4
Maximum Boring Bar Dia	Ø40 mm
Maximum Boring Bar Overhang	145 mm
OD Turning Tool Size	25 x 25 mm
Hydraulic System	
Hydraulic Pump Capacity	12 lpm
Hydraulic Power Pack Tank Capacity	45 litre
System Pressure	30 Kg/cm ²
Coolant Tank Capacity	110 litre
Overall Machine Dimensions (L x W x H)	2800 x 1600 x 2000 mm
Overall Weight (Without Packing)	~ 3100 kg

* With appropriate work holding

Note: Owing to continuous up-gradation of our products, the specification may change and to be reconfirmed at the time of ordering. Features shown may not be part of the standard equipment.

Manufactured by:

Ace Designers Ltd.

Registered Office - Plot No.7 & 8, II Phase, Peenya Industrial Area, Bangalore - 560 058, India

Tel : +91-80-2218 6700, Fax : +91-80-2218 6723, E-mail : info@acedesigners.co.in, CIN: U29199KA1986PLC007816

INDIA-Marketed & Serviced by **Micromatic®**

Ahmedabad +91 7925471145; Ambattur +91 98407 85521; Aurangabad +91 240 2552309; Bangalore +91 80 40200555; Belgaum +91 99800 02597; Bommasandra +91 80 27834836;

Chakan +91 2135 322002; Chennai +91 44 40440700; Coimbatore +91 422 4506183, 6588595; Delhi +91 11 22414232/ 42448095; Faridabad +91 129 4047000; Gurgaon +91 124 4745500 / 4745500;

Hyderabad +91 40 23070496; Indore +91 73899 39190, 73899 39191; Jamshedpur +91 657 6539931; Kolhapur +91 230 2460444, 2460123; Kolkata +91 33 26710158 / 2710100 / 033-64578825

Ludhiana +91 97791 28296; Mumbai +91 22 26861009/1976/7271/7272; Nasik +91 253 6610254; Pune +91 20 40712111/27479661/9662; Rajkot +91 7698000728 Ranipet +91 4172 272732;

Rohtak +91 8295043311; Rudrapur +91 95570 30224, +91 97201 06532; Tambaram +91 44 22265531; Thane +91 22 25829062 Trichy +91 431 2443066 Chandigarh +91 99141 91057 Bhiwadi +91 99581 09777

INTERNATIONAL

Germany +49 (0) 172 231 6688 Shanghai +86 (21) 586 650 31/32; Switzerland +41 32 652 58 41

Email : salesmmt@acemicromatic.com

