

# SUPER JOBBER

**ACE**<sup>®</sup>  
DESIGNERS

**AceMicromatic**<sup>®</sup>  
Group Company



## HORIZONTAL TURNING CENTER

### Machine Features

- Powerful AC Spindle motor
- High speed 3500 rpm spindle
- Thermally stabilised spindle
- Hardened and ground box type
- 20 m/min rapid traverse rate
- Pre-tension ball screw support
- 0.45 sec. turret Index time
- 100% ball bar tested
- Separate coolant tank-easy maintenance

### Standard Accessories

- AC spindle & axes drives
- Hardened and ground box guideways
- Heavy duty bi-directional turret
- Tailstock with live center
- Automatic centralized oil lubrication
- Hydraulic power operated chuck (Ø200 mm)
- AC unit for electricals
- Programmable quill
- 3 tier lamp
- Rigid tapping
- Drain line oil cooler
- Basic hydraulic system
- OD tool holder clamping block (8 nos)
- Boring bar holder (4 nos)
- Facing tool holder (2 nos)
- Set of sleeves

### Optional Accessories

- Hydraulic power operated Chuck (Ø250 mm)
- Voltage stabilizer - 25 kVA
- Chip conveyor rear/side
- TPM - Trak productivity monitoring system
- LASER calibrated axes

XL - Hardened & ground box guideways

**THINK** Turning<sup>®</sup>  
Ace Designers

THE LARGEST MACHINE TOOL GROUP IN INDIA

Follow us on :



Ace Designers



@acedesignersblr



@acedesigners



www.acemicromatic.net

## Machining Range

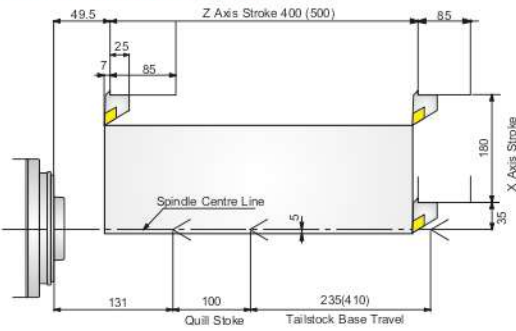

## Interference Diagram

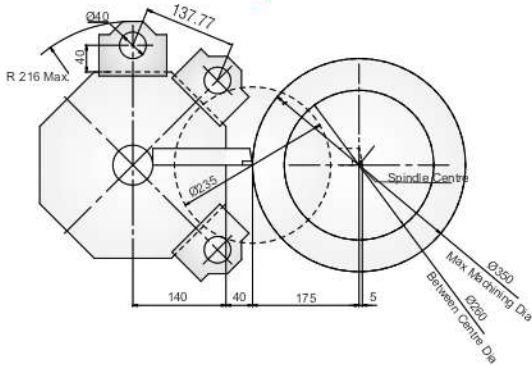

## Power Torque Diagram

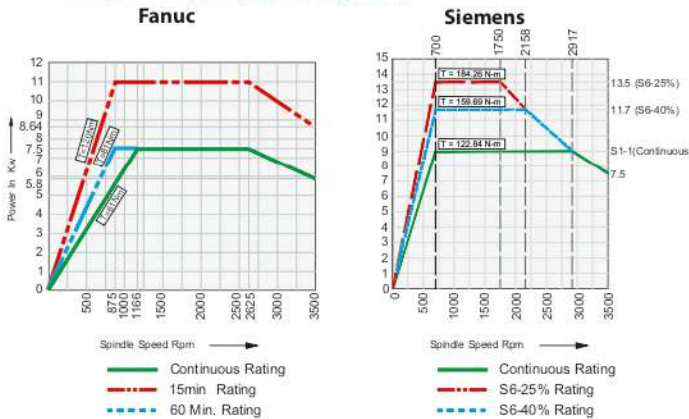

## Overall Views

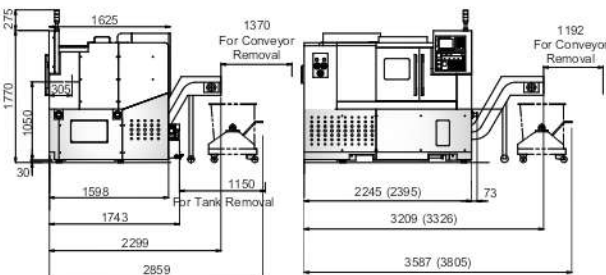

Manufactured by:

**Ace Designers Ltd.**

Plant I - Plot No.7 & 8, II Phase, Peenya Industrial Area, Bangalore - 560 058, India

Tel : +91-80-2218 6700, Fax : +91-80-2218 6723, E-mail : info@acedesigners.co.in, CIN: U29199KA1986PLC007816

INDIA-Marketed & Serviced by **Micromatic®**

Ahmedabad +91 7925471145; Ambattur +91 98407 85521; Aurangabad +91 240 2552309; Bangalore +91 80 40200555; Belgaum +91 99800 02597; Bommasandra +91 80 27834836; Chakan +91 2135 322002; Chennai +91 44 40440700; Coimbatore +91 422 4506183, 6588595; Delhi +91 11 22414232/ 42448095; Faridabad +91 129 4047000; Gurgaon +91 124 4745500 / 4745500; Hyderabad +91 40 23070496; Indore +91 73899 39190, 73899 39191; Jamshedpur +91 657 6539931; Kolhapur +91 230 2460444, 2460123; Kolkata +91 33 26710158 / 2710100 / 033-64578825; Ludhiana +91 97791 28296; Mumbai +91 22 26861009/1976/7271/7272; Nasik +91 253 6610254; Pune +91 20 40712111/27479661/9662; Rajkot +91 7698000728; Ranipet +91 4172 272732; Rohtak +91 8295043311; Rudrapur +91 95570 30224, +91 97201 06532; Tambaram +91 44 22265531; Thane +91 22 25829062; Trichy +91 431 2443066; Chandigarh +91 99141 91057; Bhiwadi +91 99581 09777

## INTERNATIONAL

Germany +49 (0) 172 231 6688; Shanghai +86 (21) 586 650 31/32; Switzerland +41 32 652 58 41

Email: salesmmt@acemicromatic.com

## Specifications

## Super Jobber

<b>Control System</b>	Fanuc/Siemens
<b>Capacity</b>	
Swing Over Bed	500 mm
Distance Between Centers	425/(550)mm
Maximum Turning Dia	350 mm
Between Centre Turning Dia	260 mm
Maximum Turning Length	400(500)* mm
<b>Spindle</b>	
Spindle Nose	A2-6
Bore Through Spindle	63mm
Front Bearing Bore	100mm
Maximum Bar Capacity	51*mm
Maximum Spindle speed	3500 rpm
Spindle Motor Power (Fanuc - 15 min. Rating) (Siemens - S6-25%) (Siemens - S6 - 40%)	Fanuc-11 kW Siemens - 13.5 kW Siemens - 11.7 kW
Spindle Motor Power (Continuous Rating)	Fanuc - 7.5/ Siemens - 9 kW
Full Power Range	Fanuc 1166 - 2625 rpm Siemens 700- 2917 rpm
Standard Chuck Size	200 mm
<b>Axes</b>	
Type of Guideways	Hardened & Ground Box type steel
X-Axis Stroke	180 mm
Z-Axis Stroke	400(500) mm
X & Z Axes Rapid Rate	20 m/min.
<b>Tooling</b>	
Number of Tools Maximum	8
Boring Bar Dia Maximum	40 mm
OD Turning Tool Size	25 x 25 mm
<b>Tailstock</b>	
Tailstock Base Travel	235 (410) mm
Tailstock Quill Travel	100 mm
Tailstock Quill Dia.	80 mm
Quill Taper	MT-4
<b>Hydraulic System</b>	
Hydraulic Pump Capacity	14 lpm
Hydraulic Power Pack	45 litre
Tank Capacity	
System Pressure	30 Kg/cm <sup>2</sup>
Coolant Tank Capacity	110 litre
<b>Overall Machine Dimensions</b> (L x W x H)	2250 x 1750 x 1770 mm (2400x1750x1700)
<b>Overall Weight</b> (Without Packing)	~ 3750kg

\* With appropriate workholding

( ) Figures in bracket for 500 version

Owing to continuous up-gradation of our products, the specification may change and to be reconfirmed at the time of ordering. Features shown may not be part of the standard equipment.

