

**Sales and Services**

**INDIA**

<b>NORTH</b>		
<b>Delhi</b> T: +91 11 49849380 E: mmtdel@acemicromatic.com <b>Gurgaon</b> T: +91 124 4745500 E: mmtgur@acemicromatic.com <b>Rohtak</b> T: +91 98188 73444 E: mmtktsales@acemicromatic.com	<b>Faridabad</b> T: +91 129 4047000 E: mmtfbd@acemicromatic.com <b>Ludhiana</b> T: +91 161 5018296 E: mmtljb@acemicromatic.com	<b>Rudrapur</b> T: +91 97201 06532 E: mmtukd@acemicromatic.com <b>Chandigarh</b> T: +91 99141 91057 E: mmtchdsales@acemicromatic.com
<b>EAST</b>		
<b>Jamshedpur</b> T: +91 657 2383750 E: mmtjam@acemicromatic.com	<b>Kolkata</b> T: +91 9830110933 E: mmtcal@acemicromatic.com	
<b>WEST</b>		
<b>Ahmedabad</b> T: +91 99242 89892 E: mmtahm@acemicromatic.com <b>Aurangabad</b> T: +91 240 2552309 E: mmtaur@acemicromatic.com <b>Indore</b> T: +91 73899 39190 E: mmtindri@acemicromatic.com <b>Nasik</b> T: +91 22 26861976 E: mmtbom@acemicromatic.com	<b>Pune - Chakan</b> T: +91 98906 23205 E: mmtpune@acemicromatic.com <b>Pune - Chinchwad</b> T: +91 20 40712111 E: mmtpune@acemicromatic.com <b>Kolhapur</b> T: +91 98906 23202 E: mmtkapa@acemicromatic.com <b>Mumbai</b> T: +91 22 26867271 E: mmtbom@acemicromatic.com	<b>Mumbai - Thane</b> T: +91 22 25829062 E: mmtbom@acemicromatic.com <b>Rajkot</b> T: +91 28272 87003 E: mmtroj@acemicromatic.com
<b>SOUTH</b>		
<b>Bangalore - Peenya</b> T: +91 80 40200555 E: mmtblr@acemicromatic.com <b>Bangalore - Bommasandra</b> T: +91 80 27834836 E: mmtbms@acemicromatic.com <b>Belgaum</b> T: +91 99800 02597 E: mmtbgm@acemicromatic.com <b>Chennai - Ambattur</b> T: +91 44 26178001 / 03 E: mmtche@acemicromatic.com	<b>Chennai - Sriperumbudur</b> T: +91 44 26178001 / 03 E: mmtche@acemicromatic.com <b>Chennai - Tambaram</b> T: +91 98407 85523 E: mmttbms@acemicromatic.com <b>Coimbatore</b> T: +91 422 4506183 E: mmtcbe@acemicromatic.com <b>Hyderabad</b> T: +91 40 23070496 E: mmthyd@acemicromatic.com	<b>Ranipet</b> T: +91 98407 85521 E: mmtipt@acemicromatic.com <b>Trichy</b> T: +91 98432 65434 E: mmttry@acemicromatic.com

**INTERNATIONAL**

<b>Germany</b> T: +49 1732025654 E: vinayb@acemicromatic.com	<b>China (Shanghai)</b> T: +86 (21) 5866 5031 / 32 E: roguramachandran@acemicromatic.com
--	--

Manufactured by:



**Ace Designers Ltd.**

Plot No: 7 & 8, 3 Phase, Peenya Industrial Area, Bengaluru - 560 058, INDIA  
 Tel: +91-80-2218 6700, Fax: +91-80-2218 6723,  
 Email: info@acedesigners.com



Follow us on:



VTL SERIES / MKD / MARZO / REV04



www.acemicromatic.net



# VERTICAL TURNING CENTERS

VTL-25 VTL-30 VTL-40

**THINK** Turning®  
 Ace Designers

## FEATURES

Ace Vertical turning center combine power, rigidity and versatility with increased capacity. Wide access to the chuck zone facilitates ease of loading and unloading of parts. Linear motion guideways on X & Z axes ensure better positioning and repeatability.

This machine is ideal for turning heavy, large diameter components like fly wheels, brake drums, big size gears, etc. The machine is conducive for easy loading and unloading of heavy components. This machine occupies smaller floor space than a horizontal turning machine that can turn comparable sized parts.



VTL-40 Bed

## Spindle

The cartridge type spindle is assembled and tested in a controlled clean room environment. The bearing configuration gives very high stiffness to the spindle assembly in both axial and radial directions. The bearings are grease lubricated for life. A high torque spindle motor provides power for heavy stock removal.



## Axes

X and Z axes feature large diameter precision ground ball screws supported at each end by precision class ball screw support bearings. Ball screws are pre-tensioned to minimize the effect of temperature growth. Heavy duty linear motion guides are widely spaced to ensure stability. Ball screws and LM guides are protected with the help of telescopic covers. Automatic metered lubrication is provided to both LM guides and ball screws.

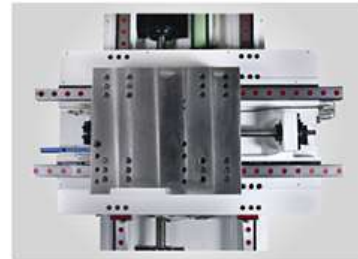

## Overload Tripping Clutch

Overload trip clutch is provided on both axes to minimise the damage caused in the event of accident. Hydraulic counterbalance is provided for z axis to counter the effect of gravity on slide unit thus ensuring the maximum availability of motor torque for cutting. It also helps to prevent the fall of slide in case of Z axis clutch trip.



## Turret

Bi-directional tool turret indexes in either direction for shortest indexing time. It is completely enclosed & robust in mechanism with oil bath lubrication. Three piece, Hirth coupling allows the tool disc to be indexed without lifting. It ensures repeatability, positioning accuracy and rigidity.



## Structural Design Optimised For Accurate Machining

- The structure is optimized using FEM technique.
- Virtual prototyping helped in arriving robust design maximizing tool point stiffness, minimizing vibration and improving power utilization.
- Bed & Column castings are grade 25 cast iron. The structure is heavily ribbed box type construction to provide high rigidity at different cutting conditions and are thermally seasoned.

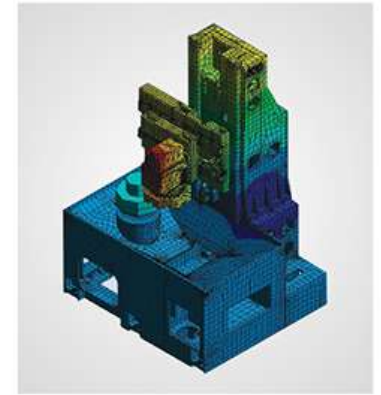

## Spindle Testing

All spindle units undergo stringent testing in a controlled environment, including thermal stabilisation to ensure guaranteed performance. Temperature of spindle on running condition is monitored to ensure optimal bearing longevity by stabilising it thermally.

### Ball Bar Testing

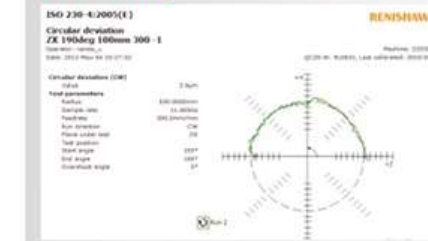

### Computerised Spindle Stabilization

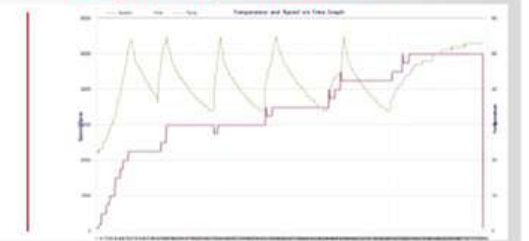

## Standard Features

- Cartridge type spindle
- AC spindle drives and axes drives
- High speed bi-directional tool Turret
- Heavy duty LM Guideways
- Automatic centralised oil lubrication
- Built-in lighting system
- Hydraulic counter balance system for Z axis
- Torque enhancement by Star-delta (Optional for VTL-25/ VTL-30 / VTL-30Plus)

## Optional Features

- Overload trip clutches on both axes
- Basic hydraulic system
- Coolant system with rear chip tray
- OD turning tool blocks (8 Nos)
- Boring bar holders (4 Nos)
- Facing tool holders (2 Nos)
- One set of sleeves for boring bars
- Fully tooled up solutions to meet customer needs
- Chip conveyor at rear only
- A wide variety of power operated work-holding (chucks, collets, fixtures, etc) and tooling
- 12 station Turret
- Auto door
- ZF Gearbox

# VTL-25L / VTL-25R



L - Left Hand  
R- Right Hand

Image shown-VTL 25 ( Left hand version)  
Machine can be offered in Right hand version also

## Machining Range

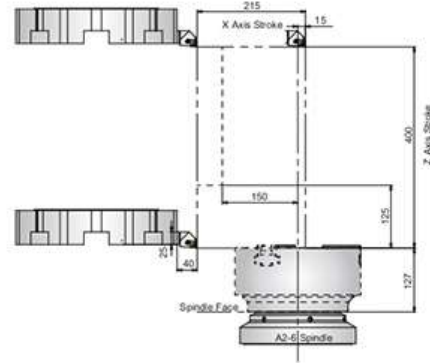

## Interference Diagram

### 8 Station

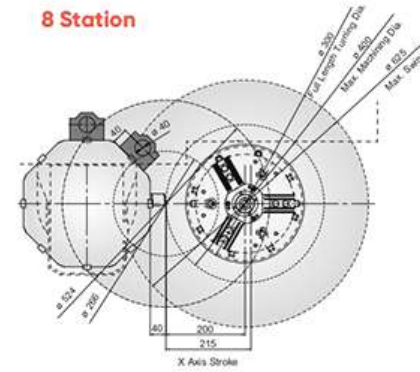

### 12 Station

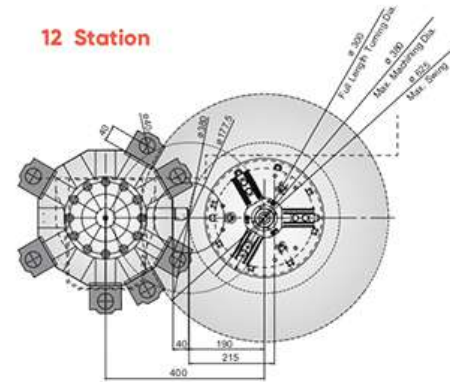

## Specifications

Model	Units	VTL-25
Control System		Fanuc/Siemens
<b>Capacity</b>		
Swing over Bed (Ø)	mm	625
Swing over carriage (Ø)	mm	300
Maximum Turning Dia	mm	400
Maximum Turning Length <sup>1</sup>	mm	400
<b>Spindle</b>		
Spindle Size / Nose		A2-6
Max Spindle Speed	rpm	3000
Spindle Motor Power Fanuc (Continuous)	kW	11
Spindle Motor Power Fanuc (30min rating)	kW	15
Full Power Range Fanuc	rpm	375-3000
Spindle Motor Power Siemens ( Continuous)	kW	17
Spindle Motor Power Siemens ( S6-40%)	kW	17
Full Power Range Siemens	rpm	512-2200
<b>Axis</b>		
X-Axis stroke	mm	215
Z Axis stroke	mm	400
X & Z Axes Guideways		Linear Motion
X & Z Axes rapid	m/min	20
<b>Tooling</b>		
Turret Type		BTP-100
No of Stations	mm	8(12)
Max Boring Bar Dia	mm	40
OD Turning Tool Size	mm	25 x 25
<b>Coolant System</b>		
Coolant Tank Capacity	l (litre)	260
<b>Hydraulic System</b>		
Hydraulic Pump Capacity	lpm	14
Hydraulic Power Pack Tank Capacity	l (litre)	45
Over all Dimensions (LxWxH)	mm	1600x1750x2550
Over all Weight (without packing)	kg	~ 4500

Note: Specifications are correct at the time of print. Owing to continuous up-gradation of our products, the specification may change and to be reconfirmed at the time of ordering

<sup>1</sup> Refer Interference Diagram ( ) Values mention in bracket are optional

## Overall Views

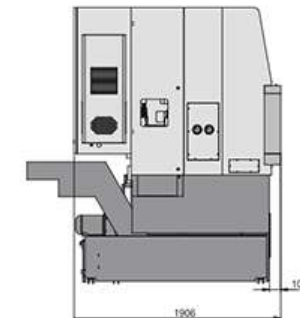

All dimensions in mm

## Power Torque Diagram

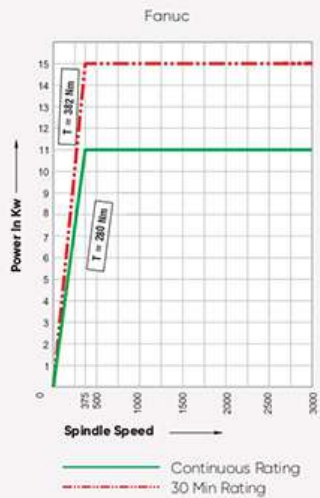

# VTL-30



## Machining Range

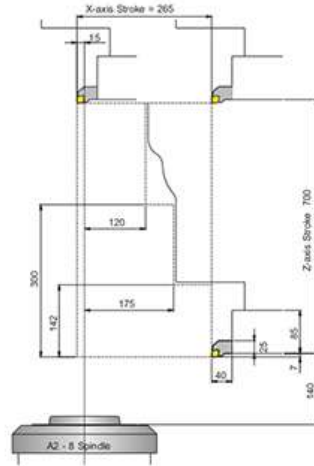

## Interference Diagram

### 8 Station

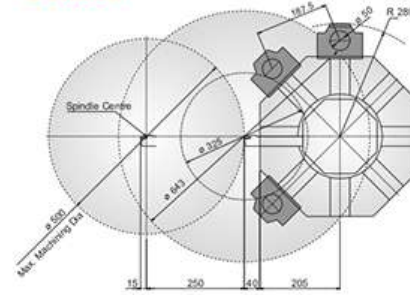

### 12 Station

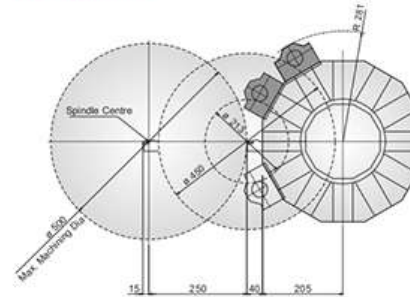

## Specifications

Model	Units	VTL-30
Control System		Fanuc/Siemens
<b>Capacity</b>		
Swing over Bed (Ø)	mm	800
Swing over carriage (Ø)	mm	240
Maximum Turning Dia	mm	500
Maximum Turning Length <sup>1</sup>	mm	700
<b>Spindle</b>		
Spindle Size / Nose		A2-8
Max Spindle Speed	rpm	2500
Spindle Motor Power Fanuc (Continuous)	kW	18.5
Spindle Motor Power Fanuc (30min rating)	kW	22
Full Power Range Fanuc	rpm	320-1920
Spindle Motor Power Siemens (Continuous)	kW	28
Spindle Motor Power Siemens (56-40%)	kW	28
Full Power Range Siemens	rpm	455-2000
<b>Axis</b>		
X-Axis stroke	mm	265
Z Axis stroke	mm	700
X & Z Axes Guideways		Linear Motion
X & Z Axes rapid	m/min	20
<b>Tooling</b>		
Turret Type		BTP-125
No of Stations	mm	8
Max Boring Bar Dia	mm	50
OD Turning Tool Size	mm	25 x 25
<b>Coolant System</b>		
Coolant Tank Capacity	l (litre)	200
<b>Hydraulic System</b>		
Hydraulic Pump Capacity	lpm	14
Hydraulic Power Pack Tank Capacity	l (litre)	45
Over all Dimensions (LxWxH)	mm	3350x2210x2620
Over all Weight (without packing)	kg	~ 7000

## Power Torque Diagram

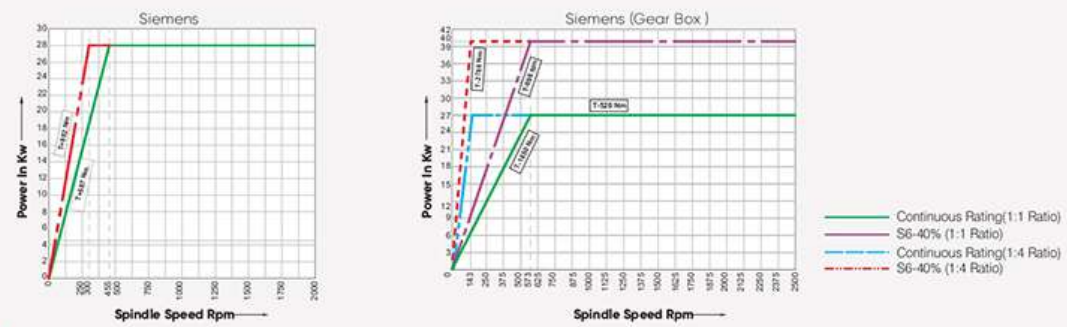
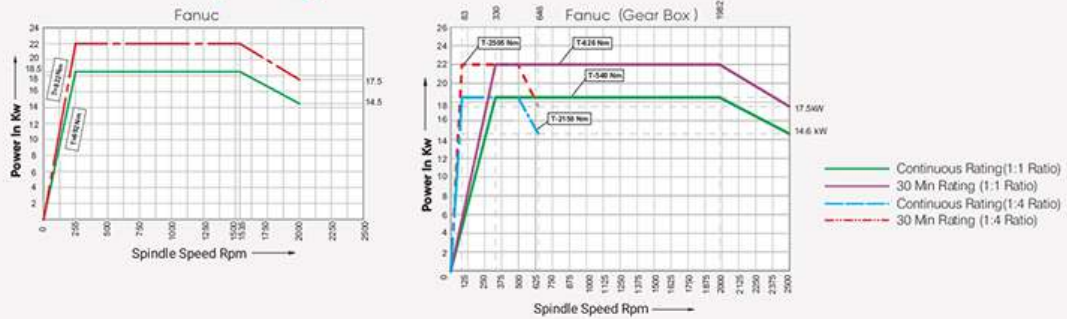

## Overall Views

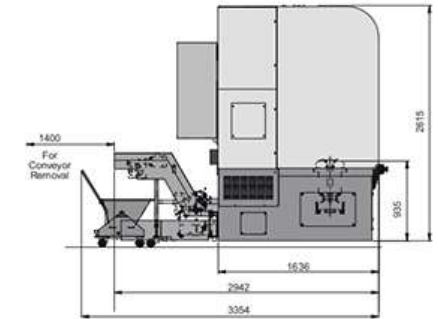
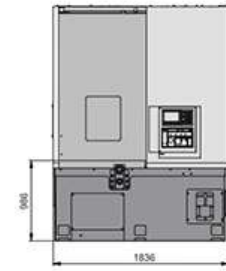

Note: Specifications are correct at the time of print. Owing to continuous up-gradation of our products, the specification may change and to be reconfirmed at the time of ordering.  
<sup>1</sup> Refer Interference Diagram

All dimensions in mm

# VTL-30 Plus



## Machining Range

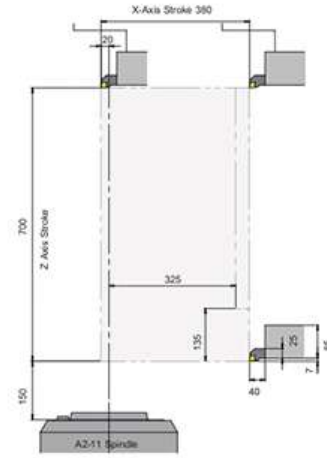

## Interference Diagram

### 8 Station

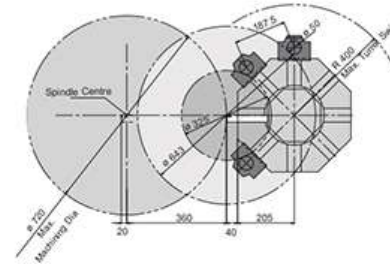

### 12 Station

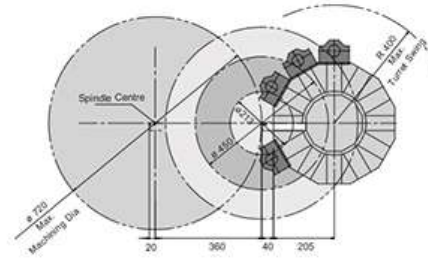

## Specifications

Model	Units	VTL-30Plus
Control System		Fanuc/Siemens
<b>Capacity</b>		
Swing over Bed (Ø)	mm	1000
Swing over carriage (Ø)	mm	650
Maximum Turning Dia	mm	720
Maximum Turning Length <sup>1</sup>	mm	700
<b>Spindle</b>		
Spindle Size / Nose		A2-11
Max Spindle Speed	rpm	2000
Spindle Motor Power Fanuc (Continuous)	kW	18.5
Spindle Motor Power Fanuc (30min rating)	kW	22
Full Power Range Fanuc	rpm	255-2000
Spindle Motor Power Siemens ( Continuous)	kW	28
Spindle Motor Power Siemens ( S6-40%)	kW	28
Full Power Range Siemens	rpm	455-2000
<b>Axis</b>		
X-Axis stroke	mm	380
Z Axis stroke	mm	700
X & Z Axes Guideways		Linear Motion
X & Z Axes rapid	m/min	20
<b>Tooling</b>		
Turret Type		BTP-125
No of Stations	mm	8(12)
Max Boring Bar Dia	mm	50(40)
OD Turning Tool Size	mm	25 x 25
<b>Coolant System</b>		
Coolant Tank Capacity	l (litre)	200
<b>Hydraulic System</b>		
Hydraulic Pump Capacity	lpm	14
Hydraulic Power Pack Tank Capacity	l (litre)	45
Over all Dimensions (LxWxH)	mm	2210x3230x2950
Over all Weight (without packing)	kg	~ 10000

## Power Torque Diagram

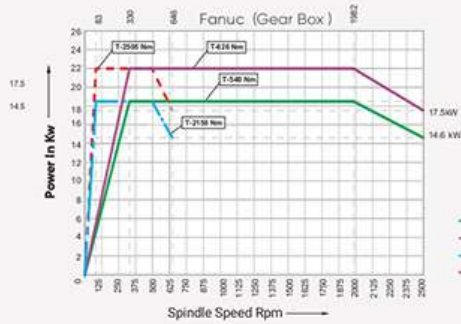
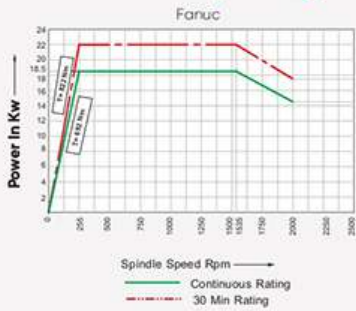

- Continuous Rating (1:1 Ratio)
- 30 Mn Rating (1:1 Ratio)
- Continuous Rating (1:4 Ratio)
- 30 Mn Rating (1:4 Ratio)

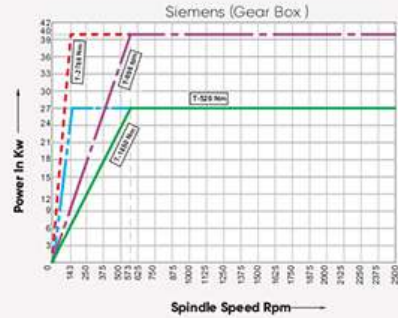
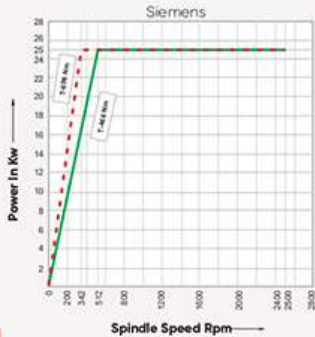

- Continuous Rating (1:1 Ratio)
- S6-40% (1:1 Ratio)
- Continuous Rating (1:4 Ratio)
- S6-40% (1:4 Ratio)

## Overall Views

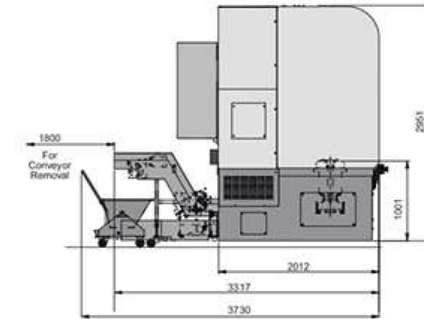
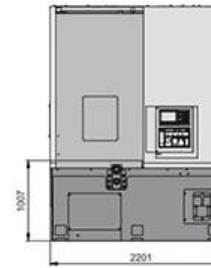

Note: Specifications are correct at the time of print. Owing to continuous up-gradation of our products, the specification may change and to be reconfirmed at the time of ordering.

<sup>1</sup> Refer Interference Diagram

( ) Values mentioned in bracket are optional

# VTL-40



## Machining Range

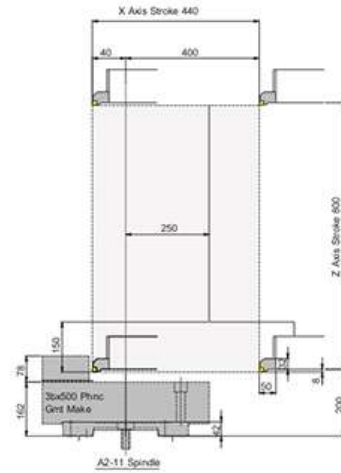

## Interference Diagram

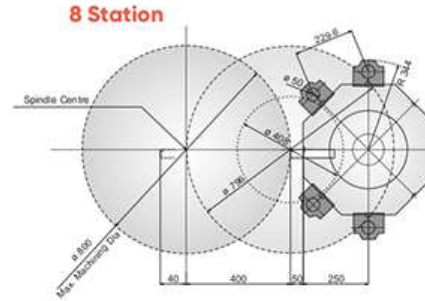

## 12 Station

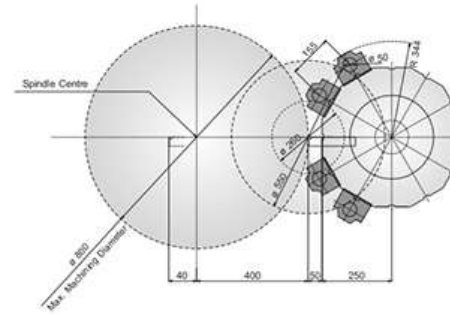

## Specifications

Model	Units	VTL-40
Control System		Fanuc/Siemens
<b>Capacity</b>		
Swing over Bed (Ø)	mm	1000
Swing over carriage (Ø)	mm	500
Maximum Turning Dia	mm	800
Maximum Turning Length <sup>1</sup>	mm	800
<b>Spindle</b>		
Spindle Size / Nose		A2-11
Max Spindle Speed	rpm	2000
Spindle Motor Power Fanuc (Continuous)	kW	22
Spindle Motor Power Fanuc (30min rating)	kW	30
Full Power Range Fanuc	rpm	535-1777
Spindle Motor Power Siemens (Continuous)	kW	27
Spindle Motor Power Siemens (S6-40%)	kW	38
Full Power Range Siemens	rpm	320-1500
<b>Axis</b>		
X-Axis stroke	mm	440
Z Axis stroke	mm	800
X & Z Axes Guideways		Linear Motion
X & Z Axes rapid	m/min	20
<b>Tooling</b>		
Turret Type		BTP-160
No of Stations	mm	8
Max Boring Bar Dia	mm	50
OD Turning Tool Size	mm	32 x 32
<b>Coolant System</b>		
Coolant Tank Capacity	l (litre)	200
<b>Hydraulic System</b>		
Hydraulic Pump Capacity	lpm	14
Hydraulic Power Pack Tank Capacity	l (litre)	45
Over all Dimensions (LxWxH)	mm	2210x2620x3250
Over all Weight (without packing)	kg	~ 10000

## Power Torque Diagram

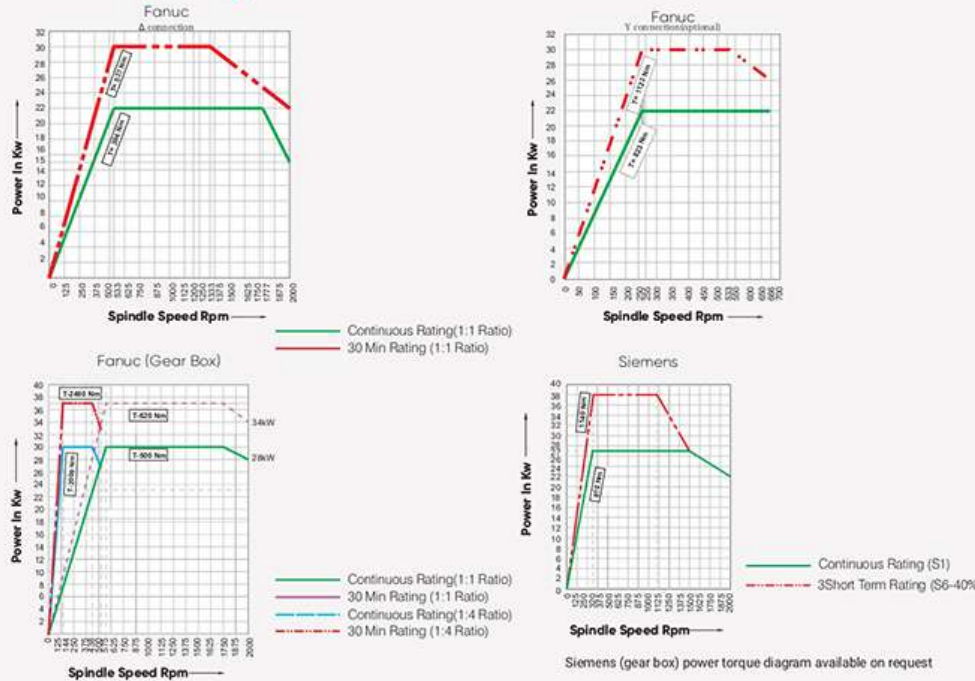

## Overall Views

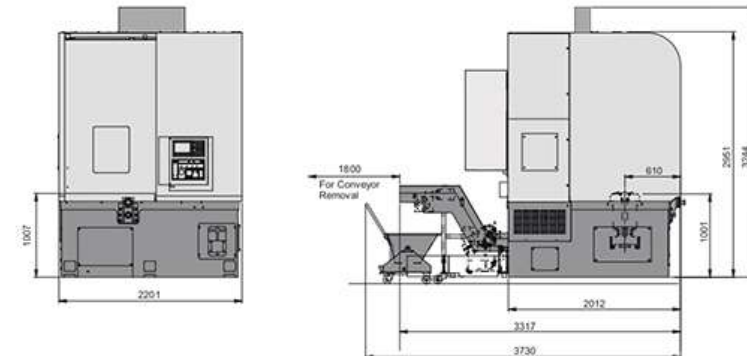

Note: Specifications are correct at the time of print. Owing to continuous up-gradation of our products, the specification may change and to be reconfirmed at the time of ordering.

1 Refer Interference Diagram

# VTL-30M



M-Turnmill

Available with only Left hand version

## Interference Diagram

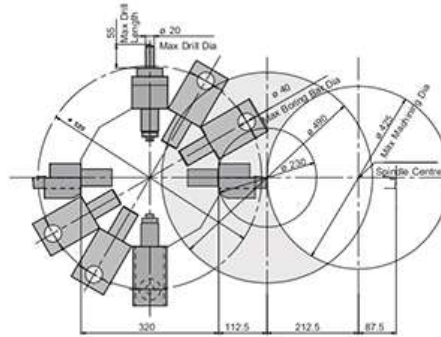

## Machining Range

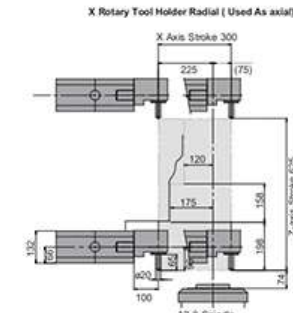
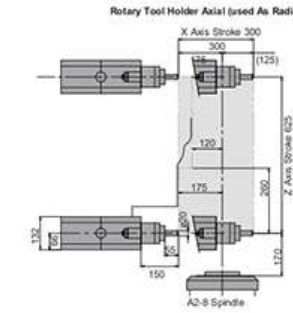
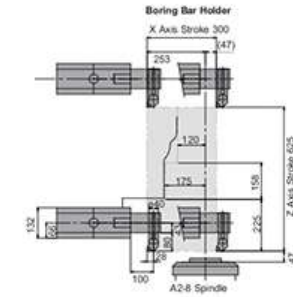
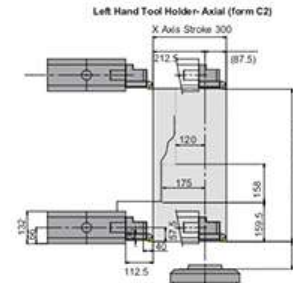

## Specifications

Model	Units	VTL-30M
Control System		Fanuc/Siemens
<b>Capacity</b>		
Swing over Bed (Ø)	mm	800
Swing over carriage (Ø)	mm	240
Maximum Turning Dia	mm	425
Maximum Turning Length <sup>1</sup>	mm	625
<b>Spindle</b>		
Spindle Size / Nose		A2-B
Max Spindle Speed	rpm	2500
Spindle Motor Power Fanuc (Continuous)	kW	18.5
Spindle Motor Power Fanuc (30min rating)	kW	22
Full Power Range Fanuc	rpm	320-1920
Spindle Motor Power Siemens ( Continuous)	kW	28
Spindle Motor Power Siemens ( S6-40%)	kW	28
Full Power Range Siemens	rpm	455-2000
<b>Axis</b>		
X-Axis stroke	mm	300
Z Axis stroke	mm	625
X & Z Axes Guideways		Linear Motion
X & Z Axes rapid	m/min	20
<b>Tooling</b>		
Turret Type		Radial Servo
No of Stations	mm	12
Max.Boring Bar Dia	mm	40
OD Turning Tool Size	mm	25 x 25
Rotary Tool Motor Power	kW	4.5
<b>Coolant System</b>		
Coolant Tank Capacity	l (litre)	200
<b>Hydraulic System</b>		
Hydraulic Pump Capacity	lpm	14
Hydraulic Power Pack Tank Capacity	l (litre)	45
Over all Dimensions (LxWxH)	mm	1840x2900x2950
Over all Weight (without packing)	kg	~ 6500

Note: Specifications are correct at the time of print. Owing to continuous up-gradation of our products, the specification may change and to be reconfirmed at the time of ordering.

<sup>1</sup> Refer Interference Diagram

## Overall Views

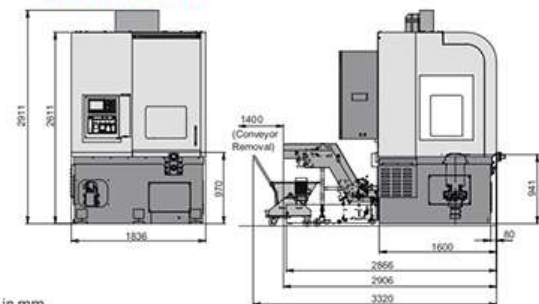

All dimensions in mm

## Power Torque Diagram

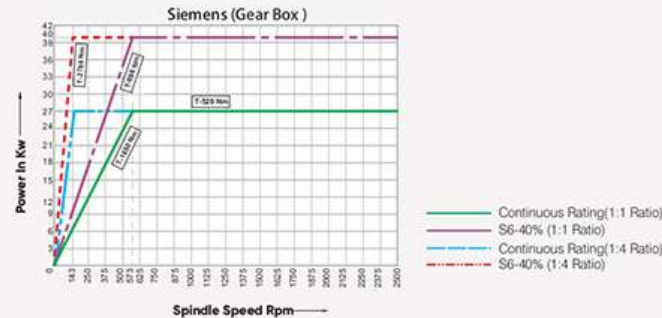
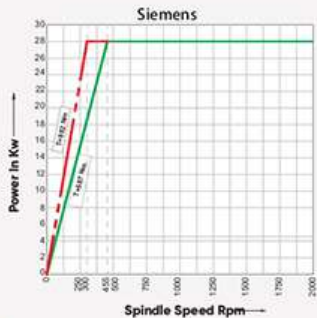
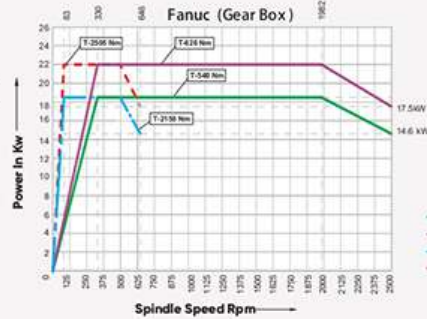
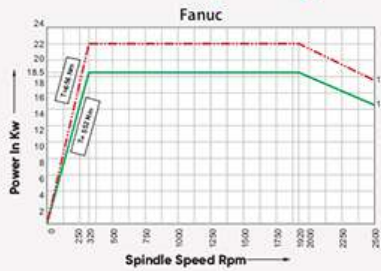

# VTL-40M



M-Turnmill

Available with only Right hand version

## Interference Diagram

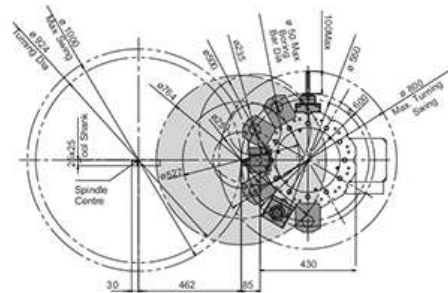

## Machining Range

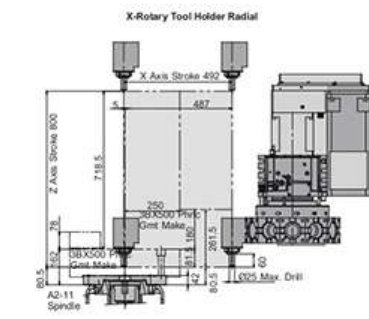
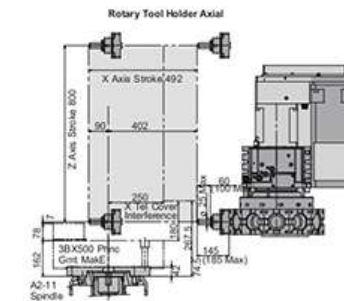
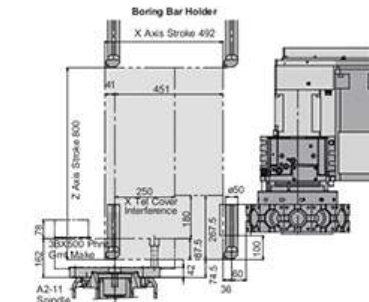
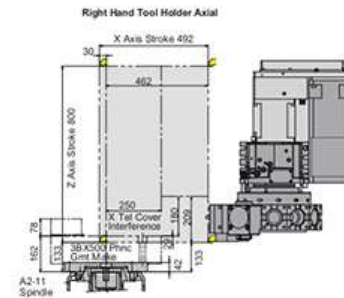

## Specifications

Model	Units	VTL-40M
Control System		Fanuc/Siemens
<b>Capacity</b>		
Swing over Bed (Ø)	mm	1000
Swing over carriage (Ø)	mm	500
Maximum Turning Dia	mm	924
Maximum Turning Length <sup>1</sup>	mm	800
<b>Spindle</b>		
Spindle Size / Nose		A2-11
Max Spindle Speed	rpm	2000
Spindle Motor Power Fanuc (Continuous)	kW	22
Spindle Motor Power Fanuc (30min rating)	kW	30
Full Power Range Fanuc	rpm	535-1777
Spindle Motor Power Siemens (Continuous)	kW	27
Spindle Motor Power Siemens (S6-40%)	kW	38
Full Power Range Siemens	rpm	320-1500
<b>Axis</b>		
X-Axis stroke	mm	500
Z Axis stroke	mm	800
X & Z Axes Guideways		Linear Motion
X & Z Axes rapid	m/min	20
<b>Tooling</b>		
Turret Type		Radial Servo
No of Stations	mm	12
Max Boring Bar Dia	mm	50
ØD Turning Tool Size	mm	25 x 25
Rotary Tool Motor Power	kW	5
<b>Coolant System</b>		
Coolant Tank Capacity	l (litre)	200
<b>Hydraulic System</b>		
Hydraulic Pump Capacity	lpm	14
Hydraulic Power Pack Tank Capacity	l (litre)	45
Over all Dimensions (LxWxH)	mm	2210x3375x3250
Over all Weight (without packing)	kg	~ 9500

Note: Specifications are correct at the time of print. Owing to continuous up-gradation of our products, the specification may change and to be reconfirmed at the time of ordering.

1 Refer Interference Diagram

## Overall Views

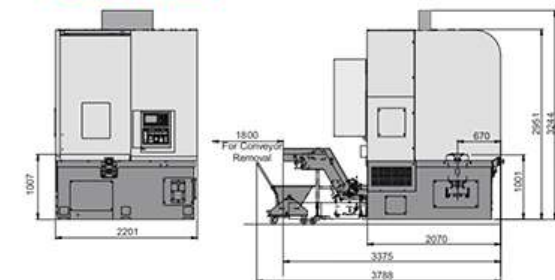

All dimensions are in mm

All dimensions in mm

## Power Torque Diagram

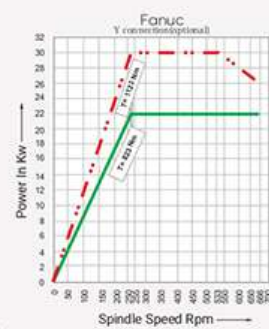
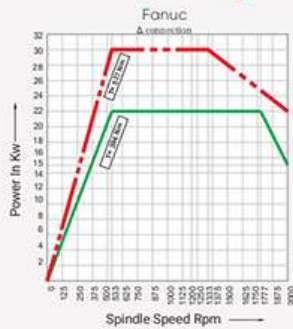

### Fanuc (Gear Box)

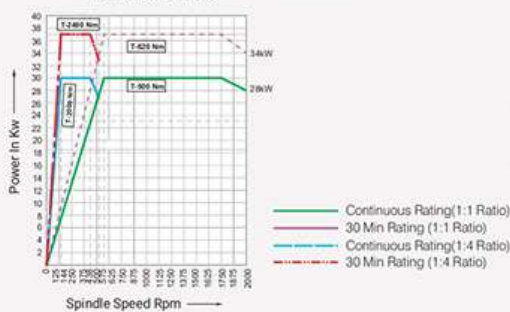

### Siemens

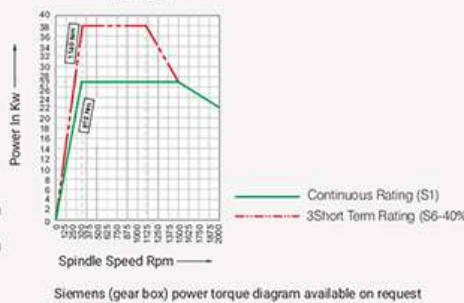

Siemens (gear box) power torque diagram available on request