

Marketed and Serviced by:

Micromatic®

Corporate Office : Plot No. 240-241, 11th Main Road, 3rd Phase, Peenya Industrial Area, Bangalore-560 058,
Ph: 080 40200555, E-mail: salesmmt@acemicromatic.com

Sales and Services

INDIA

| | | |
|---|--|---|
| NORTH | | |
| Delhi T: +91 11 49849380 E: mmtdel@acemicromatic.com | Faridabad T: +91 129 4047000 E: mmtfbd@acemicromatic.com | Rudrapur T: +91 97201 06532 E: mmtukd@acemicromatic.com |
| Gurgaon T: +91 124 4745500 E: mmtgur@acemicromatic.com | Ludhiana T: +91 161 5018296 E: mmtljb@acemicromatic.com | Chandigarh T: +91 99141 91057 E: mmtchdsales@acemicromatic.com |
| Rohtak T: +91 98188 73444 E: mmttrksales@acemicromatic.com | | |
| EAST | | |
| Jamshedpur T: +91 657 2383750 E: mmtjam@acemicromatic.com | Kolkata T: +91 98301 10933 E: mmtcal@acemicromatic.com | |
| WEST | | |
| Ahmedabad T: +91 99242 89892 E: mmtahm@acemicromatic.com | Pune - Chakan T: +91 98906 23205 E: mmtpun@acemicromatic.com | Mumbai - Thane T: +91 22 25829062 E: mmtbom@acemicromatic.com |
| Aurangabad T: +91 240 2552309 E: mmtaur@acemicromatic.com | Pune - Chinchwad T: +91 20 40712111 E: mmtpun@acemicromatic.com | Rajkot T: +91 28272 87003 E: mmtraj@acemicromatic.com |
| Indore T: +91 73899 39190 E: mmtindra@acemicromatic.com | Kolhapur T: +91 98906 23202 E: mmtkop@acemicromatic.com | |
| Nasik T: +91 22 26861976 E: mmtbom@acemicromatic.com | Mumbai T: +91 22 26867271 E: mmtbom@acemicromatic.com | |
| SOUTH | | |
| Bangalore - Peenya T: +91 80 40200555 E: mmtblr@acemicromatic.com | Chennai - Sriperumbudur T: +91 44 26178001 / 03 E: mmtche@acemicromatic.com | Ranipet T: +91 98407 85521 E: mmtprt@acemicromatic.com |
| Bangalore - Bommasandra T: +91 80 27834836 E: mmtbms@acemicromatic.com | Chennai - Tambaram T: +91 98407 85523 E: mmttbma@acemicromatic.com | Trichy T: +91 98432 65434 E: mmttry@acemicromatic.com |
| Belgaum T: +91 99800 02597 E: mmtbgm@acemicromatic.com | Coimbatore T: +91 422 4506183 E: mmtcbe@acemicromatic.com | |
| Chennai - Ambattur T: +91 44 26178001 / 03 E: mmtche@acemicromatic.com | Hyderabad T: +91 40 23070496 E: mmthyd@acemicromatic.com | |

INTERNATIONAL

| | |
|--|--|
| Germany T: +49 1732025654 E: vinayb@acemicromatic.com | China (Shanghai) T: +86 (21) 5866 5031 / 32 E: raguramachandran@acemicromatic.com |
|--|--|

Manufactured by:



Ace Designers Ltd.

Plot No.7 & 8, 8 Phase, Peenya Industrial Area, Bengaluru - 560 058, INDIA
Tel: +91-80-2218 6700, Fax: +91-80-2218 6723,
Email: info@acedesigners.com



Follow us on:



VANTAGE SERIES (INDIA) HQDURE/04



www.acemicromatic.net



VANTAGE SERIES

HORIZONTAL TURNING CENTERS

THINK Turning®
Ace Designers

Ace Micromatic®
Group Company



The Vantage

Ace Vantage turning centers combine power, rigidity and productivity. These are high precision CNC Turning centers with C and Y axes capability to cater to a wide variety of machining needs like milling, drilling, tapping and front/back-end turning applications in a single setup which increases the machine capability significantly.

All the stations are capable of driving a Milling, Drilling or Tapping head attachments. For live tooling to be effective, the spindle provides precise circular orientation of the workpiece and during live tool operations, the spindle is locked by a powerful brake, which disengages while turning and indexing. The spindle is designed for heavy duty cutting.

Power up series motor are offered for increased torque at lower spindle rpm.

C-Axis

C-axis provides bi-directional motion that can be interpolated with X / Z motion. The rotating cutters are mounted on the tool turret and they move in the same two axes of motion as the turning tools.

Y-Axis

Y-axis is a third linear axis which enables rotary cutters to machine across the spindle center line. To get Y-axis motion, an extra set of ways is used to move the live tool across the face of the spindle.

Thereby production shops can realize quickly the production advantages of integrating milling / drilling and turning operations. Full contouring movement of the workpiece allows profiling cuts to be made using simultaneous X-Y-Z axes motion with the C-axis. This makes it a true four-axis machine.

Architecture

Major structural components have been combined into one solid platform. True slant bed design provides the most rigid foundation possible for headstock, turret, tailstock and sub spindle.

Ribbing is reinforced to the optimum and to make it one piece bed structure. Mechanical rigidity has been increased substantially thereby machine is capable of performing heavy-duty turning / milling / drilling and maintain accuracy.



Vantage 800MY

Axes

X & Y axes are hardened and ground integral box cast iron ways. These guideways are extra wide and are precision machined for maximum strength and extra rigidity, which is required for heavy duty and interrupted turning applications.

Slide ways are bonded with "Turcite" to eliminate stick-slip, minimize wear and maintain long term accuracy.

Precision hardened and precision ground ball screws ensure the highest accuracy and durability. Plus, pre-tensioning on all axes minimizes thermal distortion.



Spindle

The cartridge type spindle is assembled and tested in a controlled clean room environment. The bearing configuration gives very high stiffness to the spindle assembly in both axial and radial directions. The bearings are grease lubricated for life. A high torque spindle motor COMPUTERISED provides power for heavy stock removal.



Turret

Bi-directional turret indexes in either direction for shortest indexing time.

These turrets are completely enclosed and robust in mechanism with oil bath lubrication. Three piece hirth coupling allows the tool disc to be indexed without lifting. It ensures repeatability, positioning accuracy and rigidity.



Spindle Testing

All spindle units undergo stringent testing in a controlled environment, including thermal stabilisation to ensure guaranteed performance. Temperature of spindle on running condition is monitored to ensure optimal bearing longevity by stabilising it thermally.

Ball Bar Testing Computerised Spindle Stabilization



Tailstock

The tailstock consists of a hydraulically operated quill that moves inside a housing. The quill and the body are independently moveable. The tailstock is supported on flat guideways. Widely spaced guideways and heavy-duty design of the tailstock ensure rigidity. footpedal or program activates the quill.



Vantage 500LM

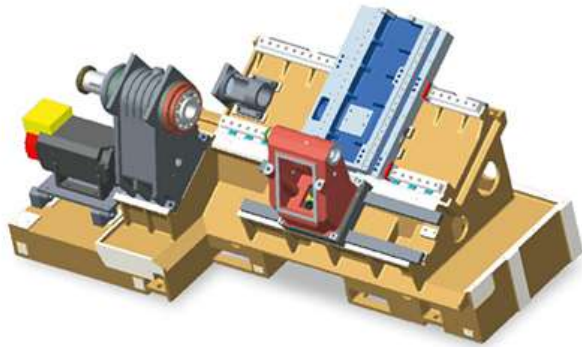

- 30 degree slant bed
- X & Z axes is LM guideways
- Large turning diameter up to 580mm (With standard Turret)
- Higher swing up to 640 mm
- Maximum turning length of 500mm
- Direct drive for X&Z Axes

LM - Linear Motion Guideways

Standard Accessories

- Cartridge type spindle
- AC spindle & axes drives
- Linear Motion Guideways
- 8 station bi-directional turret
- Tailstock with live center
- Automatic centralized oil lubrication
- Drain line oil cooler
- Basic hydraulic system
- Built-in lighting system
- Over load trip clutch for axes
- AC unit for electrical cabinets
- Door interlock

Optional Accessories

- Fully tooled up solutions to meet customer needs
- Chip conveyor at side
- A wide variety of power operated work-holding
- Auto door
- Tool touch probe
- Parts catcher
- Bar feeder
- Programmable tailstock
- Steady Rest
- 3 Tier lamp
- TPM Trak productivity monitoring system
- Built live center for tailstock

Interference diagram

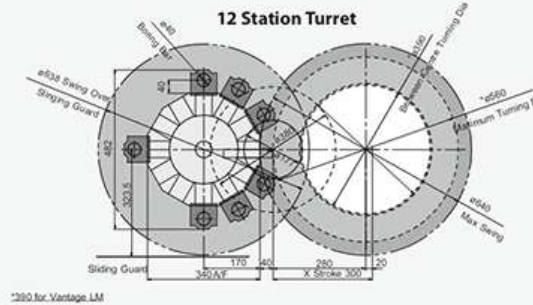
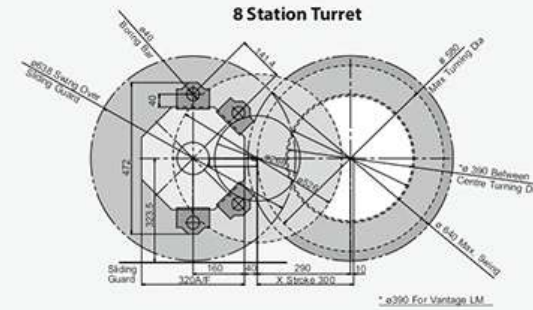

Machining range diagram

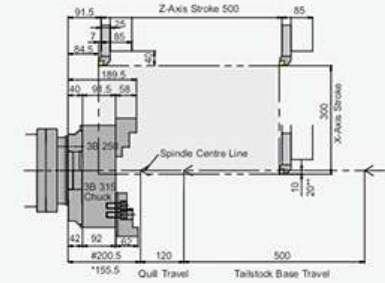

Note:
 ■ 200.5 Built In Tailstock Centre
 * 155.5 for ADD-ON Type Tailstock Centre
 ** 20 For 12 Station Turret

Power torque diagram

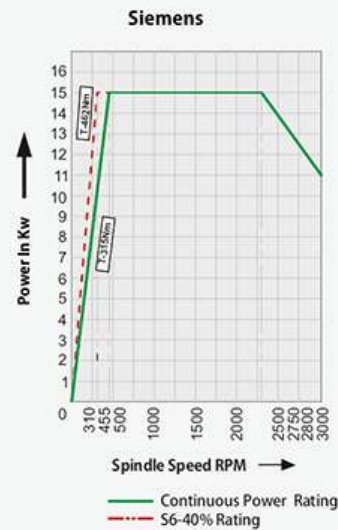
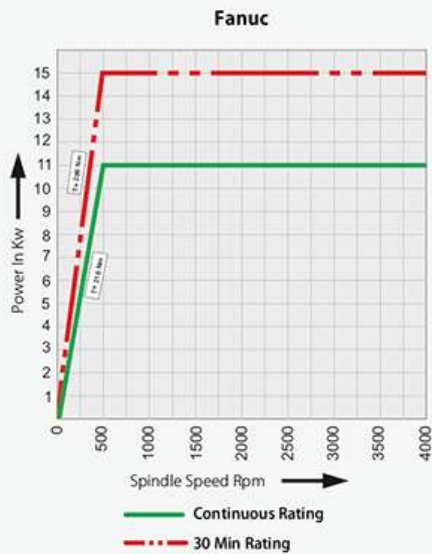

All dimensions are in mm

Overall views

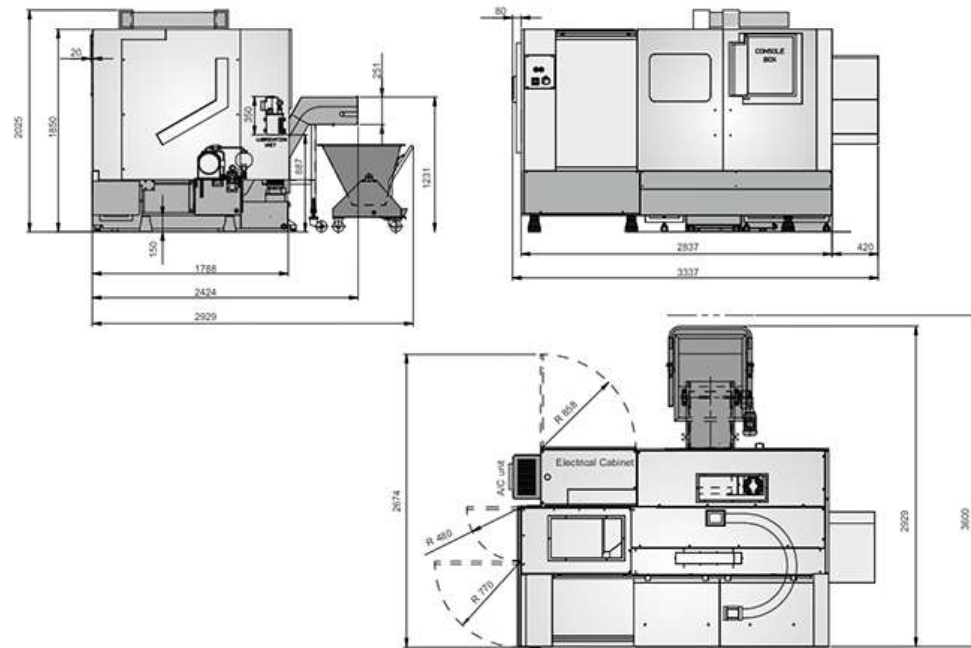

All dimensions are in mm

Vantage 800LM/XL Vantage 1000LM/XL

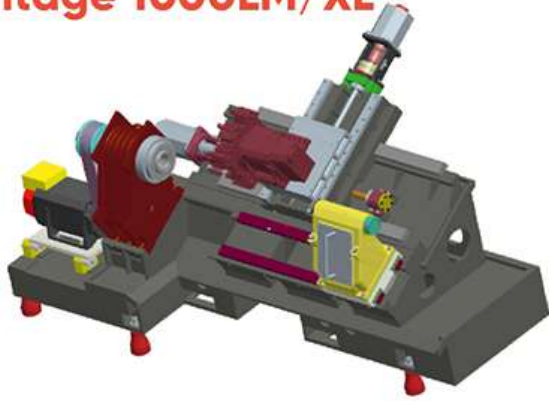

- 30 degree slant bed
- X axis is Integral guideways
- Z axis is box type hardened and ground guide ways
- Large turning diameter up to 580mm (With standard Turret)
- Higher swing up to 640 mm
- Maximum turning length of 800mm* (Vantage 800)
- Maximum turning length of 1105mm* (Vantage 1000LM)
- Direct drive for X&Z Axes

XL - Hardened Ground Guideways LM - Linear Motion Guideways
* Refer machining range diagram

Standard Accessories

- Cartridge type spindle
- AC spindle & axes drives
- Precision Guideways
- 8 station bi-directional turret
- Tailstock with live center
- Automatic centralized oil lubrication
- Drain line oil cooler
- Basic hydraulic system
- Built-in lighting system
- Over load trip clutch for axes
- AC unit for electrical cabinets
- Door Interlock

Optional Accessories

- Fully tooled up solutions to meet customer needs
- Chip conveyor at side
- A wide variety of power operated work-holding
- Auto door
- Tool touch probe
- Parts catcher
- Bar feeder
- Programmable Tailstock
- Steady Rest
- 3 Tier lamp
- TPM Trak productivity monitoring system
- Built live center for tailstock

Interference diagram

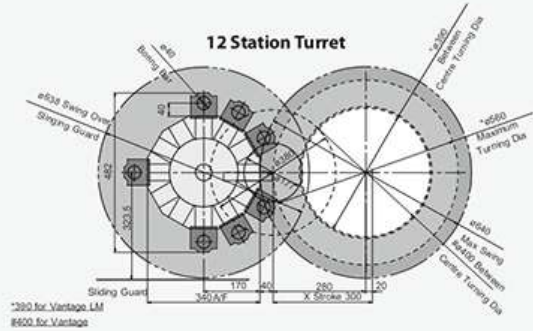
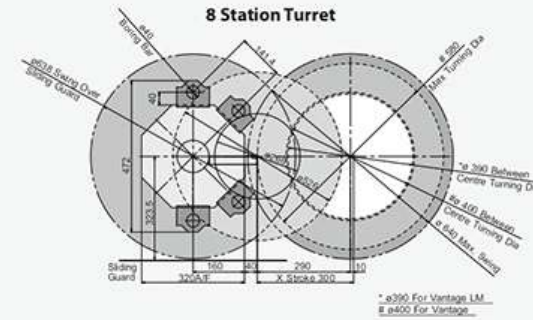

Machining range diagram

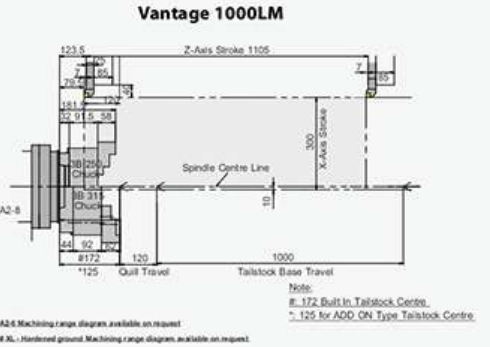
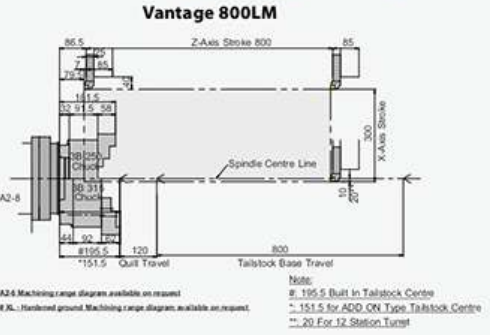

Power torque diagram

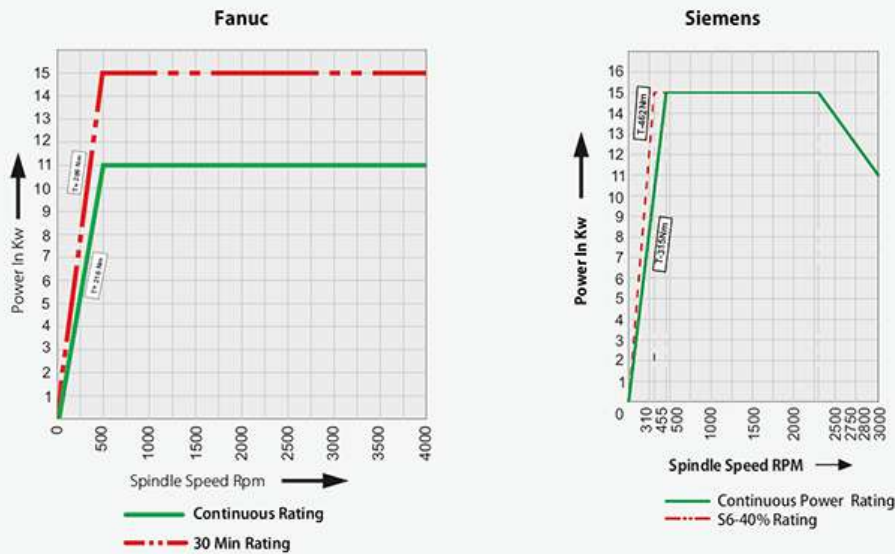

Overall views

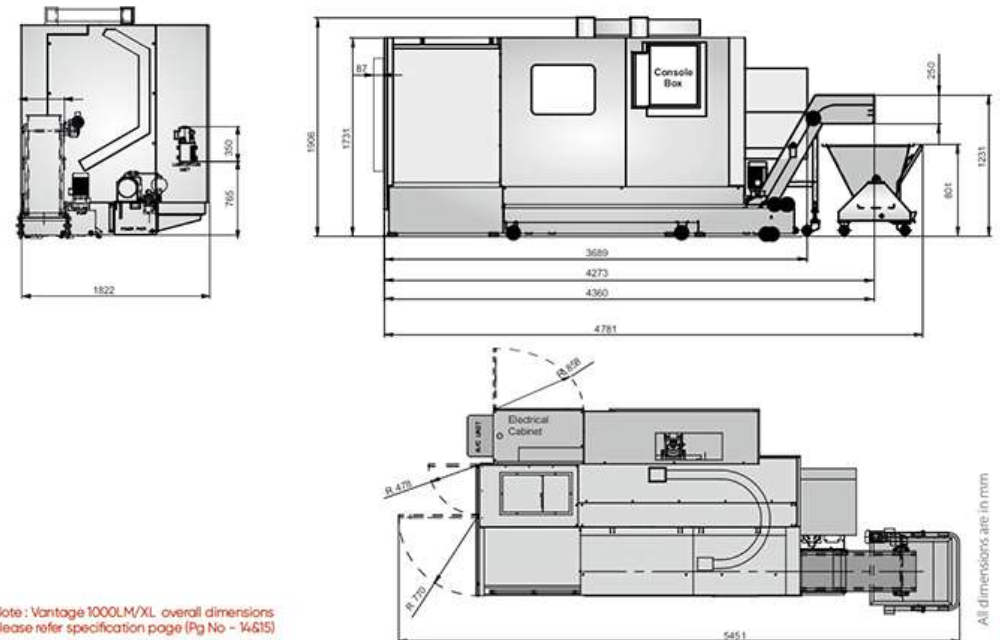

All dimensions are in mm

All dimensions are in mm

Vantage 800 M

Vantage 800 LM M

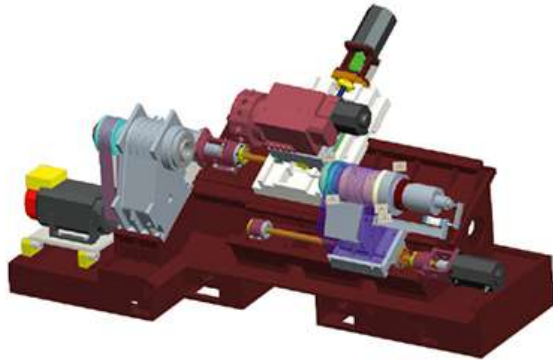

- Turnmill version with driven tools turret
- 30 degree true slant bed
- XL: X axis is Integral, Z axis is hardened and ground guide ways.
- LM: Linear Motion guideways
- Large turning diameter up to 400 mm (With standard Turret)
- Higher swing up to 640 mm

XL - Hardened Ground Guideways LM - Linear Motion Guideways M - Turnmill

Standard Accessories

- Cartridge type spindle
- AC spindle & axes drives
- Precision Guideways
- 12 station bi-directional servo turret
- Tailstock with live center
- Automatic centralized oil lubrication
- Drain line oil cooler
- Basic hydraulic system
- Built-in lighting system
- Over load trip clutch for axes
- AC unit for electrical cabinets
- Door Interlock

Optional Accessories

- Fully tooled up solutions to meet customer needs
- Chip conveyor at side or rear
- A wide variety of power operated work-holding
- Auto door
- Tool touch probe
- Parts catcher
- Bar feeder
- Programmable Tailstock
- Steady Rest
- 3 Tier lamp
- TPM Trak productivity monitoring system
- Built live center for tailstock

Interference diagram

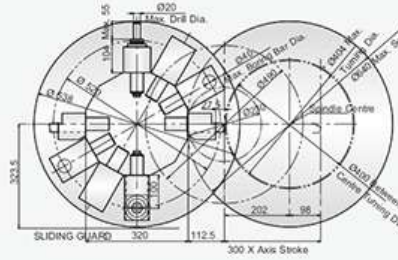

Machining range diagram

Holder Used Left Hand Over Head

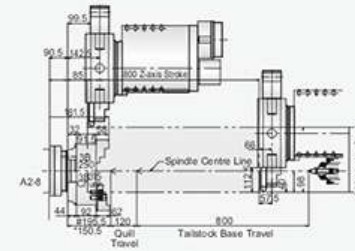

Holder Used Left Hand Short Over Head

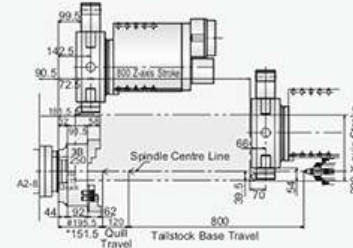

Rotary Tool Used Diplomatic Axial

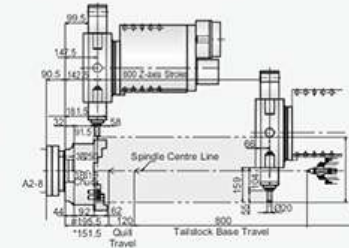

Rotary Tool Used Diplomatic Radial

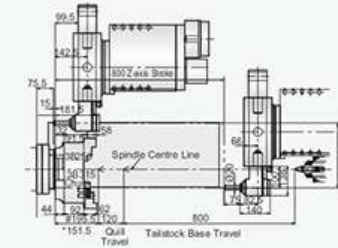

Note: A2-8 Machining range diagram available on request

Power torque diagram

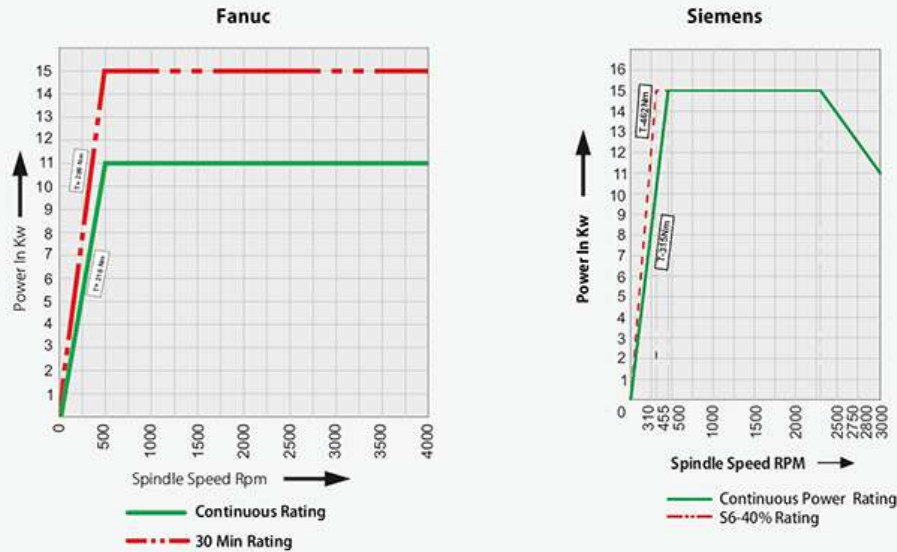

Overall views

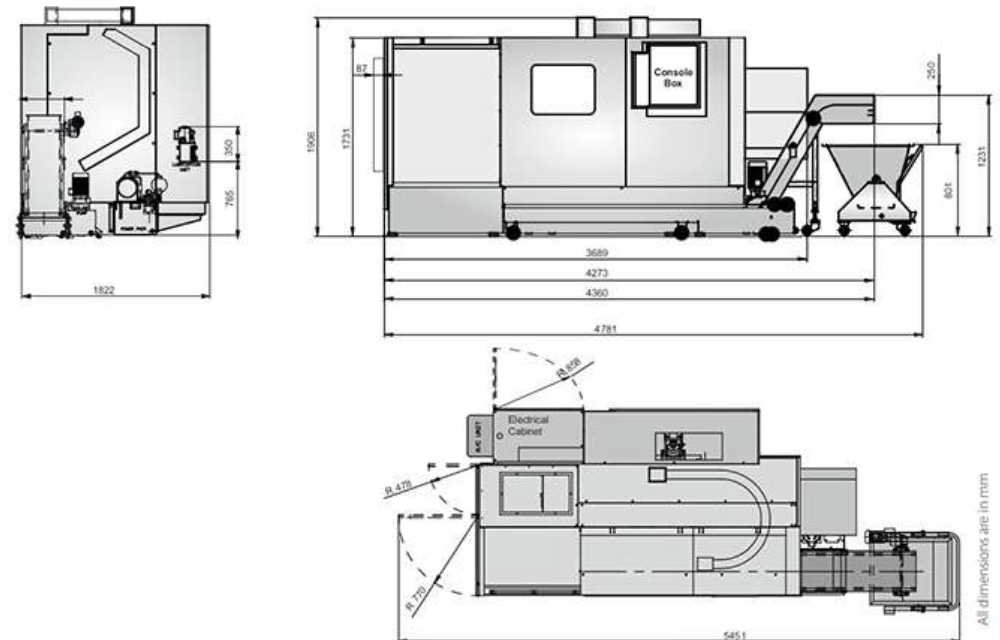

All dimensions are in mm

All dimensions are in mm

Vantage 800 MY

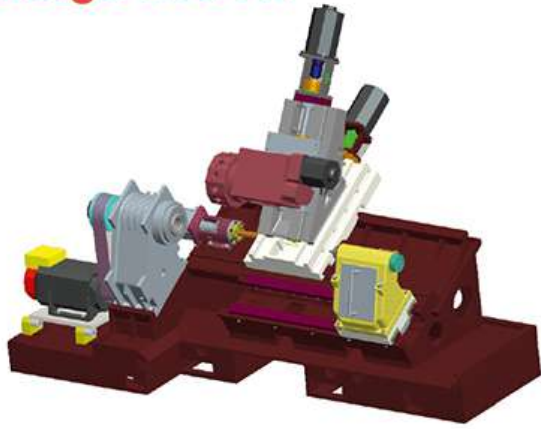

- Turnmill version with driven tools turret
- 30 degree true slant bed
- X & Y axes is with integral hardened and ground box guide ways
- Z axis is with box type hardened and ground guide ways
- Double slide construction for Y axis

M - Turnmill Y - Y Axis

Standard Accessories

- Cartridge type spindle
- AC spindle & axes drives
- Precision Guideways
- 12 Station bi-directional servo turret
- Tailstock with live center
- Automatic centralized oil lubrication
- Drain line oil cooler
- Basic hydraulic system
- Built-in lighting system
- Over load trip clutch for axes
- AC unit for electrical cabinets
- Door interlock

Optional Accessories

- Fully tooled up solutions to meet customer needs
- Chip conveyor at side or rear
- A wide variety of power operated work-holding
- Auto door
- Tool touch probe
- Parts catcher
- Bar feeder
- Programmable Tailstock
- Steady Rest
- 3 Tier lamp
- TPM Trak productivity monitoring system
- Built live center for tailstock

Interference diagram

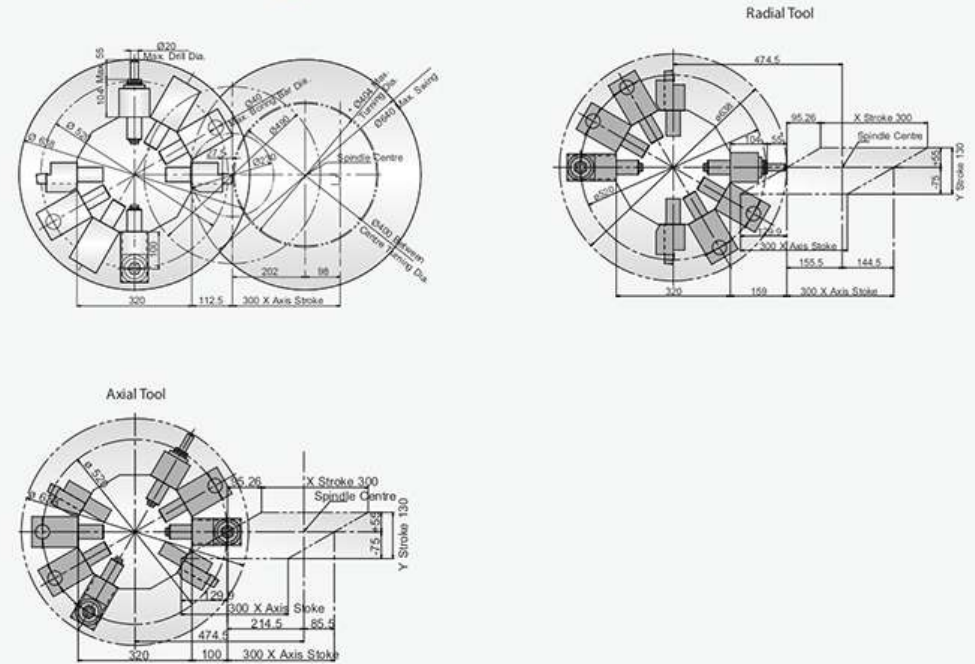

Power torque diagram

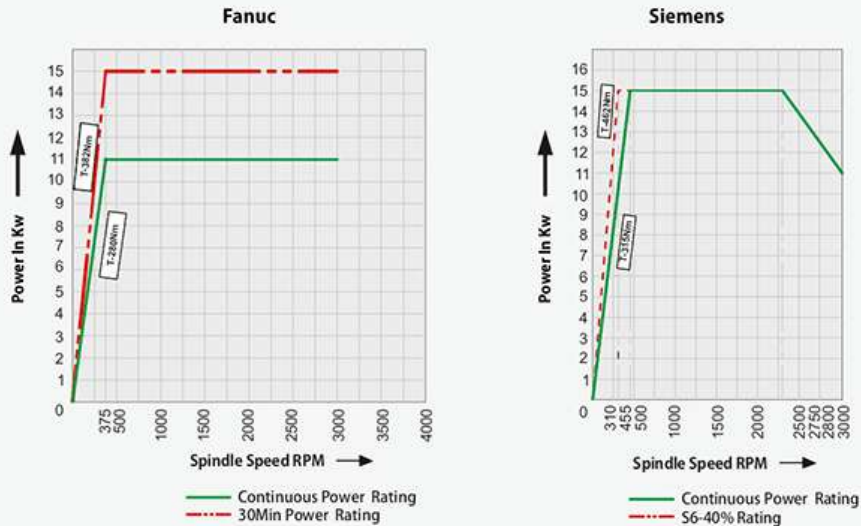

Machining range diagram

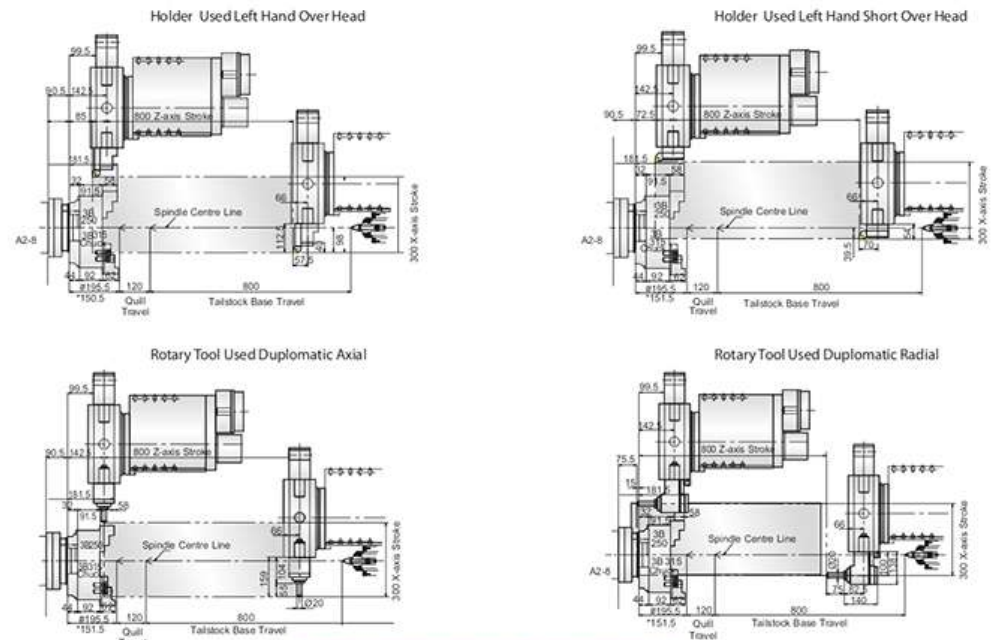

All dimensions are in mm.

Note: For overall dimensions please refer specification page (Pg No - 14)

Note: A2-4 Machining range diagram available on request

All dimensions are in mm.

Vantage 800 MSY

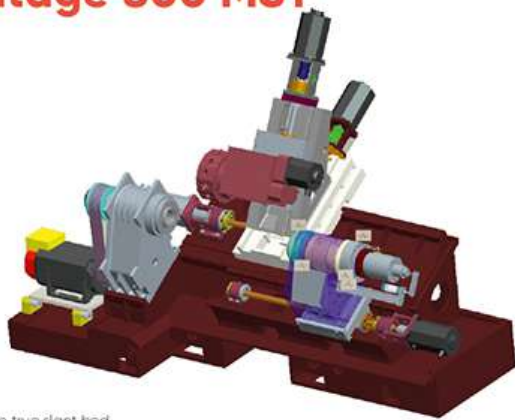

- 30 degree true slant bed
- Modular construction
- X, Y & Z axes direct
- B axis for sub spindle linear movement
- CS1 and CS2 axes for main and sub spindle
- 12 station radial tools servo turret
- Single Alpha 22S servo motor for turret indexing and rotary tools
- Hydraulic clamping / declamping for turret
- Main Spindle with Alpha P22 "Power Up" series motor – 11 / 15 KW
- Built in motor for flat nose sub spindle with 5.5 / 7.5 KW and 5000 RPM
- Double slide construction for Y axis

M - Turret Mill S - Sub Spindle Y - Y Axis

Standard Accessories

- Cartridge type spindle
- AC spindle & axes drives
- Precision Guideways
- 12 Station bi-directional servo turret
- Automatic centralized oil lubrication
- Drain line oil cooler
- Basic hydraulic system
- Built-in lighting system
- Over load trip clutch for axes
- AC unit for electrical cabinets
- Door interlock

Optional Accessories

- Fully tooled up solutions to meet customer needs
- Chip conveyor at side or rear
- A wide variety of power operated work-holding
- Auto door
- Tool touch probe
- Parts catcher
- Bar feeder
- Steady Rest
- 3 Tier lamp
- TPM Trak productivity monitoring system

Interference diagram

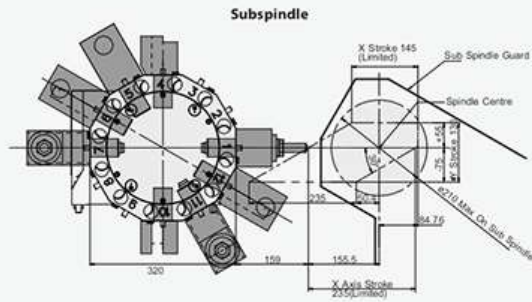
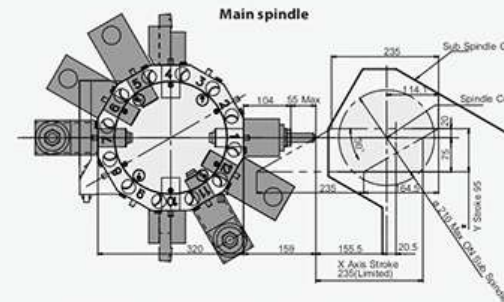
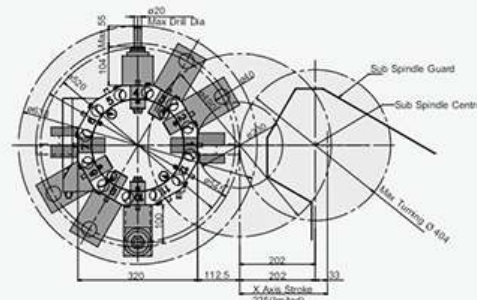

Note : Interference of radial tooling available on request.

Power torque diagram

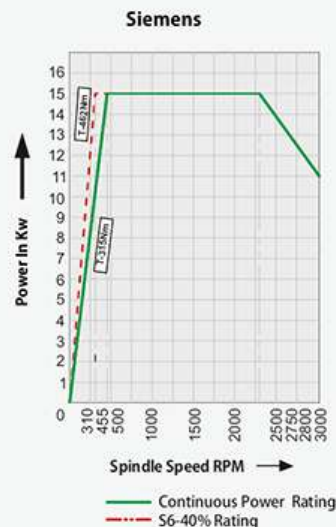
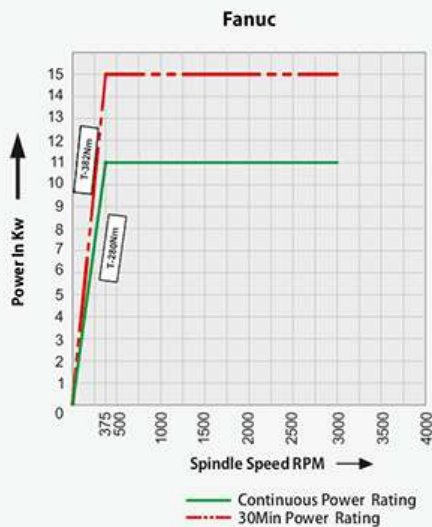

Note : Power torque diagram of subspindle available on request

Machining range diagram

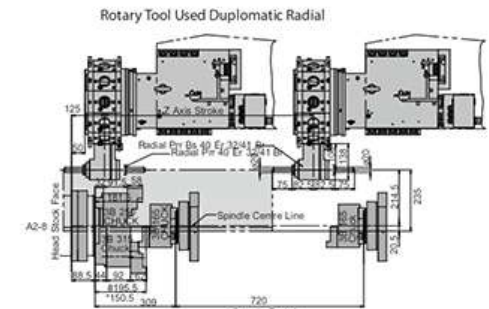
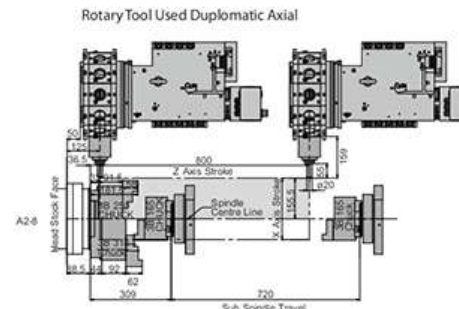
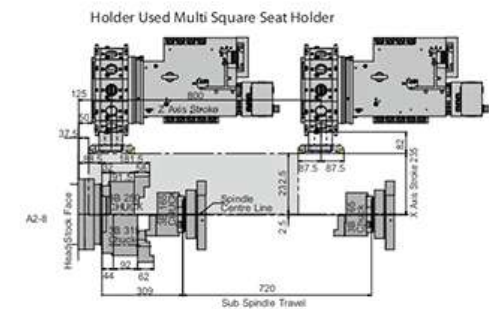
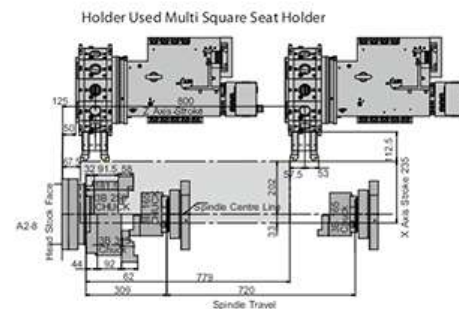

All dimensions are in mm.

Note : For overall dimensions please refer specification page (Pg No - 14)

Note : A2-6 Machining range diagram available on request

All dimensions are in mm.

Specifications

| Model | Units | Vantage 500 LM | Vantage 800 | Vantage 800 LM | Vantage 1000 LM / XL | Vantage 800 M / 800 LM M | Vantage 800 MY | Vantage 800 MSY |
|--|-----------|--------------------|---------------------------------|--------------------|----------------------|---|--------------------------------------|--------------------------------------|
| Control System | | Fanuc/Siemens | Fanuc/Siemens | Fanuc/Siemens | Fanuc/Siemens | Fanuc/Siemens | Fanuc/Siemens | Fanuc/Siemens |
| Capacity | | | | | | | | |
| Swing Over Bed | mm | 640 | 640 | 640 | 640 | 640 | 640 | 640 |
| Swing over Carriage | mm | 390 | 400 | 390 | 390 / 400 | 400/390 | 400 | 400 |
| Maximum Turning Dia | mm | 580 | 580 | 580 | 580 | 400 | 400 | 400 |
| Maximum Turning Length ¹ | mm | 500 | 800 | 800 | 1000 | 800 | 800 | 800 |
| Distance Between Centre ¹ | mm | 580 | 1025 | 1025 | 1180 | 1025 | 1025 | NA |
| Spindle | | | | | | | | |
| Spindle Size / Nose | | A2-6 (A2-B) | A2-6 (A2-B) | A2-6 (A2-B) | A2-6(A2-B) | A2-6(A2-B) | A2-B | A2-B |
| Max.Bar Capacity ³ | mm | 51(74) | 51(74) | 51(74) | 51(74) | 51(74) | 74 | 74 |
| Bore through Spindle | mm | 63(86) | 63(86) | 63(86) | 63(86) | 63(86) | 86 | 86 |
| Max.Spindle Speed | rpm | 4000(3000) | 4000(3000) | 4000(3000) | 4000(3000) | 4000(3000) | 3000 | 3000 |
| Spindle Motor Power_Fanuc (Continuous) | kW | 11 | 11 | 11 | 11 | 11 | 11 | 11 |
| Spindle Motor Power_Fanuc (30 min) | kW | 15 | 15 | 15 | 15 | 15 | 15 | 15 |
| Spindle Motor Power_Siemens (Continuous) | kW | 15 | 15 | 15 | 15 | 15 | 15 | 15 |
| Spindle Motor Power_Siemens (S6-40 %) | kW | 15 | 15 | 15 | 15 | 15 | 15 | 15 |
| Full Power Range -Fanuc | rpm | 500-4000 | 500-4000 | 500-4000 | 500-4000 | 500-4000 | 375-3000 | 375-3000 |
| Full Power Range -Siemens | rpm | 592-3030 | 592-3030 | 592-3030 | 592-3030 | 592-3030 | NA | NA |
| Sub-Spindle | | | | | | | | |
| Sub-Spindle Size / Nose | | NA | NA | NA | NA | NA | NA | Flat Nose |
| Bore Through Spindle | mm | NA | NA | NA | NA | NA | NA | 47 |
| Max. Sub-Spindle Speed | rpm | NA | NA | NA | NA | NA | NA | 5000 |
| Spindle Motor Power (Continuous/30 min) | kW | NA | NA | NA | NA | NA | NA | 5.5/7.5 |
| Full Power Range -Fanuc | rpm | NA | NA | NA | NA | NA | NA | 50-5000 |
| Axis | | | | | | | | |
| X-Axis Stroke | mm | 300 | 300 | 300 | 300 | 300 | 300 | 300 |
| X-Axis Rapid | m/min | 20 | 20 | 20 | 20 | 20 | 20 | 20 |
| X-Axis Guideways | | Linear motion | Hardened and ground Box type | Linear motion | Linear motion /HGBT | Hardened and ground box type / Linear motion | Integral type hardened and ground | Integral type hardened and ground |
| Z-Axis Stroke | mm | 500 | 800 | 800 | 1105 | 800 | 800 | 800 |
| Z-Axis Rapid | m/min | 20 | 20 | 20 | 20 | 20 | 20 | 20 |
| Z-Axis Guideways | | Linear motion | Hardened and ground Box type | Linear motion | Linear motion | Hardened and ground Box type / LM | Hardened and ground Box type | Hardened and ground Box type |
| Y-Axis Stroke | mm | NA | NA | NA | NA | NA | +55/-75 | +55/-75 |
| Y-Axis Rapid | m/min | NA | NA | NA | NA | NA | 10 | 10 |
| Y-Axis Guideways | | NA | NA | NA | NA | NA | Integral type hardened and ground | Integral type hardened and ground |
| Tooling | | | | | | | | |
| Turret Type | | BTP-100 | BTP-100 | BTP-100 | BTP-100 | Rotary Tool Turret (R) | Rotary Tool Turret (R) | Rotary Tool Turret (R) |
| Rotary Tool Motor Power | kW | NA | NA | NA | NA | 4.5 | 4.5 | 4.5 |
| No of Stations | | 8 | 8 | 8 | 8 | 12 | 12 | 12 |
| Max.Boring Bar Dia | mm | 40 | 40 | 40 | 40 | 40 | 40 | 40 |
| OD Turning Tool Size | mm | 25 x 25 | 25 x 25 | 25 x 25 | 25 x 25 | 25 x 25 | 25 x 25 | 25 x 25 |
| TailStock | | | | | | | | |
| TailStock Base Travel | mm | 500 | 800 | 800 | 1000 | 800 | 800 | NA |
| TailStock Quill Dia | mm | 80 | 80 | 80 | 100 | 80 | 80 | NA |
| TailStock Quill Travel | mm | 120 | 120 | 120 | 120 | 120 | 120 | NA |
| TailStock Quill Taper | | MT-4 | MT-4 | MT-4 | MT-5 | MT-4 | MT-4 | NA |
| Coolant System | | | | | | | | |
| Coolant Tank Capacity | l (litre) | 155 | 155 | 155 | 190 | 155 | 155 | 155 |
| Hydraulic System | | | | | | | | |
| Hydraulic Pump Capacity | lpm | 14 | 14 | 14 | 14 | 14 | 14 | 14 |
| Hydraulic Power Pack Tank Capacity | l (litre) | 45 | 45 | 45 | 45 | 45 | 45 | 45 |
| Over all Dimensions (LxWxH) | mm | 3400 x 1850 x 1860 | 3690 x 1850 x 1906 | 3690 x 1850 x 1906 | 4400 x 1900 x 1920 | 3690 x 1850 x 1906 | 3690 x 1900 x 2409 | 3690 x 1900 x 2410 |
| Over all Weight (without packing) | Kg | - 4500 | - 5500 | - 5500 | - 6000 | - 5500 | - 6000 | - 6500 |

1 Refer machining range diagram

2 Refer interference diagram

3 With appropriate workholding

LM - Linear Motion Guideways
HGBT - Hardened and ground box type
Y - Y-axis
S - Subspindle
M - Milling

() - Values are mentioned in bracket are optional

Note: Specifications correct at the time of print. Owing to continuous up-gradation of our products, the specification may change and to be reconfirmed at the time of ordering.