

WLV 24 2T

ALLOY WHEEL TURNING

ACE[®]
DESIGNERS

AceMicromatic[®]
Group Company



VERTICAL TURNING CENTER

Machine Features

- A2-11 Cartridge type spindle
- AC spindle drives and axes drives
- 6 Station twin turrets
- Hardened and ground steel bolt on guideways for all axes.
- Built-in lighting system
- Basic Hydraulic system
- Centralised oil Lubrication
- Hydraulic Counter Balance System for both Z axes
- Coolant system including twin chip trays, basic filtration and clean coolant tank along with coolant pumps

Standard Accessories

- Cooling system for electrical cabinet
- Fail safe brake for both Z axes
- High pressure coolant system with bed flushing and coolant gun

Optional Accessories

- Fully tooled up solutions for up to 24" aluminium wheels including wheel chuck and necessary tool holders and mounting blocks
- Twin chip conveyors with drum filtration to the rear
- Auto door

THINK Turning[®]
Ace Designers

THE LARGEST MACHINE TOOL GROUP IN INDIA

Follow us on :



Ace Designers



@acedesignersblr



@acedesigners



Machining Range Diagram

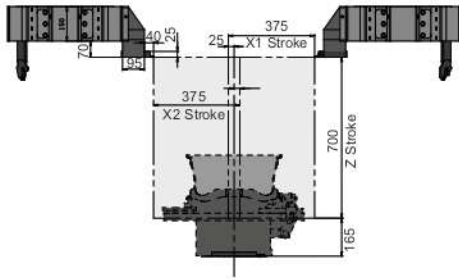

Interference Diagram

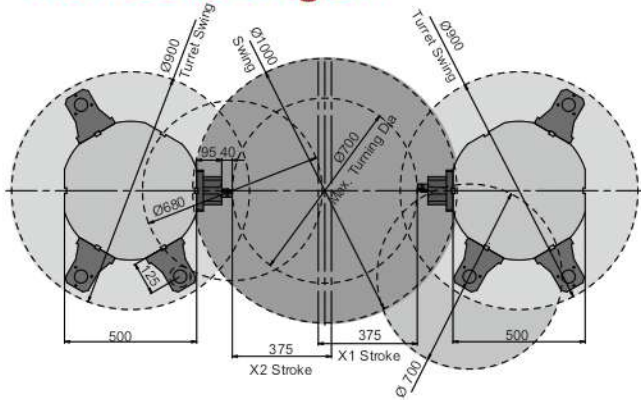

Power Torque Diagram

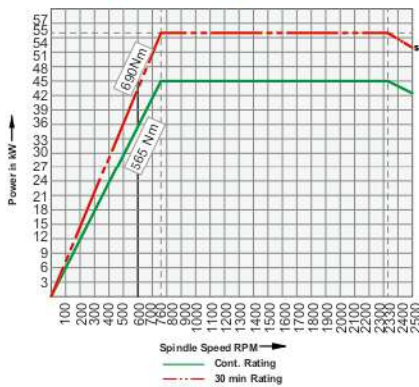

Overall View

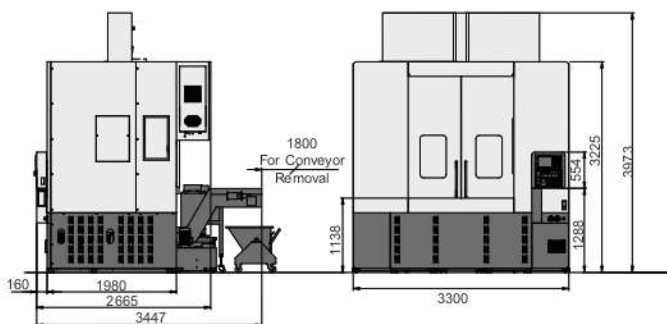

All dimensions are in mm

Specifications

WLV 24 2T

Control System	Fanuc (2 path)
Capacity	
Swing Over Bed	1000 mm
Swing over carriage	690 mm
Maximum Turning Dia.	700 mm
Maximum Turning Length	700 mm
Spindle	
Spindle Nose	A2-11
Front bearing dia	150 mm
Max. Spindle Speed	2500 rpm
Spindle Motor Power (30 min. Rating)	55 kW
Spindle Motor Power(Continuous Rating)	45 kW
Full Power Range	760-2330 rpm
Axes	
Type of Guideways	Hardened & Ground Box
X1 & X2-Axis Stroke	380 mm
Z1 & Z2-Axis Stroke	700mm
X1 & X2-Axis Rapid Rate	20 m/min.
Z1 & Z2-Axis Rapid Rate	15 m/min.
X1 & X2-Axis Motor Torque	22 Nm
Z1 & Z2-Axis Motor Torque	30 Nm
X1 & X2-Axis Ball Screw dia x pitch	40x10mm
Z1 & Z2-Axis Ball Screw dia x pitch	50x10mm
Tooling(Left & Right)	
Turret Type	Servo turret
Maximum Number of Tools	6 + 6
Maximum Boring Bar Dia	60 mm
OD Turning Tool Size	25 x 25 mm
Hydraulic System	
Hydraulic Pump Capacity	14 lpm
Hydraulic Power Pack Tank Capacity	45 litre
Coolant Tank Capacity	500 litre
Overall Machine Dimensions(L x W x H)	3300x2800x3800
Overall Weight (Without Packing)	~ 15000 kg

Note: Specification correct at the time of print. Owing to continuous up-gradation of our products, the specification may change and to be reconfirmed at the time of ordering. Features shown may not be part of the standard equipment.

Manufactured by:

Ace Designers Ltd.

Plant I - Plot No.7 & 8, II Phase, Peenya Industrial Area, Bangalore - 560 058, India

Tel : +91-80-2218 6700, Fax : +91-80-2218 6723, E-mail : info@acedesigners.co.in, CIN: U29199KA1986PLC007816

INDIA-Marketed & Serviced by **Micromatic®**

Ahmedabad +91 7925471145; Ambattur +91 98407 85521; Aurangabad +91 240 2552309; Bangalore +91 80 40200555; Belgaum +91 99800 02597; Bommasandra +91 80 27834836;

Chakan +91 2135 322002; Chennai +91 44 40440700; Coimbatore +91 422 4506183, 6588595; Delhi +91 11 22414232/ 42448095; Faridabad +91 129 4047000; Gurgaon +91 124 4745500 / 4745500;

Hyderabad +91 40 23070496; Indore +91 73899 39190, 73899 39191; Jamshedpur +91 657 6539931; Kolhapur +91 230 2460444, 2460123; Kolkata +91 33 26710158 / 2710100 / 033-64578825

Ludhiana +91 97791 28296; Mumbai +91 22 26861009/1976/7271/7272; Nasik +91 253 6610254; Pune +91 20 40712111/27479661/9662; Rajkot +91 7698000728 Ranipet +91 4172 272732;

Rohtak +91 8295043311; Rudrapur +91 95570 30224, +91 97201 06532; Tambaram +91 44 22265531; Thane +91 22 25829062 Trichy +91 431 2443066 Chandigarh +91 99141 91057 Bhiwadi +91 99581 09777

INTERNATIONAL

Germany +49 (0) 172 231 6688 Shanghai +86 (21) 586 650 31/32; Switzerland +41 32 652 58 41

Email: salesmmt@acemicromatic.com

